

Measuring current transformers of the W... series

Measuring current transformers of the W...-8000 series



Measuring current transformers
W60 – W60-8000



W20 – W20-8000 mounted on DIN rail

Device features

Measuring current transformer W...

- For residual current monitoring systems of the RCMS460/490 series
- For residual current monitors of the RCM420, RCM460 and RCM470 series
- For insulation fault location systems of the EDS460/490 and EDS470 series

Measuring current transformers W...-8000

- For insulation fault evaluators of the EDS473(E)-12, EDS474(E)-12, EDS461 and EDS491 series

Product description

Measuring current transformers of the W... and W...-8000 series are highly sensitive measuring current transformers which measure AC currents and convert them into evaluable measurement signals, in combination with residual current monitors and evaluators of the RCM resp. RCMS series.

In addition, the measuring current transformers can be used in combination with insulation fault location systems (EDS) for IT systems. They are designed to measure the test current generated by a PGH insulation fault test device or an A-ISOMETER® IRDH. In combination with insulation fault evaluators of the EDS series, the test current is converted into evaluable signals.

Connection to the respective devices is via a two-wire cable.

Installation instructions

- Make sure that all live conductors are routed through the measuring current transformer.
- Do not route shielded conductors through the measuring current transformer.
- Never route a PE conductor through the measuring current transformer!

Wiring diagram

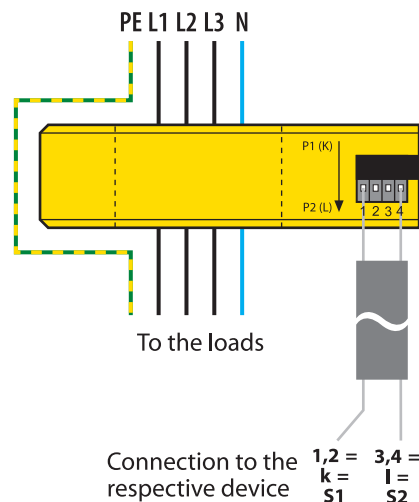

Measuring current transformer W...

Connection to the respective residual current monitoring system of the RCMS series, residual current monitor of the RCM series or to an insulation fault location system of the EDS series.

Measuring current transformers W...-8000

Connection to the respective insulation fault evaluators EDS473(E)-12, EDS474(E)-12, EDS461 and EDS491.

Approvals

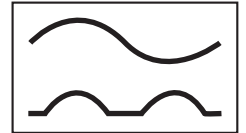

Technical data
Insulation coordination acc. to IEC 60664-1/IEC 60664-3

Rated insulation voltage	800 V
Rated impulse voltage/pollution degree	8 kV / III

CT circuit W...

Rated primary residual current	10 mA...10 A
Rated secondary residual current	0.0167 A
Rated transformation ratio K_N	10/0.0167 A
Rated burden	max. 180 Ω^*
Nominal power	0.05 VA
Frequency range	42 Hz...3 kHz
Rated continuous thermal current I_{cth}	40 A
Rated short-time thermal current I_{th}	60 x I_{cth} = 2.4 kA/1 s
Rated dynamic current I_{dyn}	2.5 x I_{th} = 6.0 kA/40 ms

CT circuit W...-8000

Rated primary residual current	1 A
Rated secondary residual current	0.125 mA
Rated transformation ratio K_N	1 A/0.125 mA
Rated burden	2400 Ω
Nominal power	0.0375 VA
Frequency range	42 Hz...3 kHz
Rated continuous thermal current I_{cth}	6 A
Rated short-time thermal current I_{th}	60 x I_{cth} = 0.36 kA/1 s
Rated dynamic current I_{dyn}	2.5 x I_{th} = 0.9 kA/40 ms

Environmental conditions

Operating temperature	-25 °C...+70 °C
Climatic class acc. to IEC 60721	
Stationary use (IEC 60721-3-3)	3K5 (except condensation and formation of ice)
Transport (IEC 60721-3-2)	2K5 (except condensation and formation of ice)
Long-time storage (IEC 60721-3-1)	1K5 (except condensation and formation of ice)
Classification of mechanical conditions IEC 60721	
Stationary use (IEC 60721-3-3)	3M4
Transport (IEC 60721-3-2)	2M2
Long-time storage (IEC 60721-3-1)	1M3

Connection

Type of connection	cage clamp spring terminal
rigid/flexible/conductor sizes	0.08...2.5/0.08...2.5 mm ² /28...12 AWG
Stripping length	8...9 mm

Connection EDS, RCM(S) measuring current transformers

Single wire ≥ 0.75 mm ²	0...1 m
Single wire, twisted ≥ 0.75 mm ²	0...10 m
Shielded cable ≥ 0.5 mm ²	0...40 m
Recommended cable	J-Y (ST) Y min. 2 x 0.8 (shielded, shield on one side connected to L-conductor, not connected to earth)

Other

Degree of protection, internal components (DIN EN 60529)	IP40
Degree of protection, terminals (IEC 60529)	IP20
Screw mounting	M5 with mounting brackets
Flammability class	UL94V-0
Product standards	IEC 60044-1
Operating manual W..., W...-8000	BP409013
Approval	UL under consideration, GOST

* The rated burden may vary depending on the respective device data sheet.

Ordering information

Type	Inside diameter	Mounting		Art. No.
		DIN rail	Mounting brackets	
W20	20 mm	×	×	B 9808 0003
W35	35 mm	×	×	B 9808 0010
W60	60 mm	×	×	B 9808 0018
W120	120 mm	--	×	B 9808 0028
W210	210 mm	--	×	B 9808 0034
W20-8000*	20 mm	×	×	B 9808 0009
W35-8000*	35 mm	×	×	B 9808 0017
W60-8000*	60 mm	×	×	B 9808 0027

Accessories

Type	Width	Art. No.
Snap-on mounting for W20-W35, W20-W35-8000*	43.5 mm	B 9808 0501
Snap-on mounting for W60, W60-8000*	50 mm	B 9808 0502

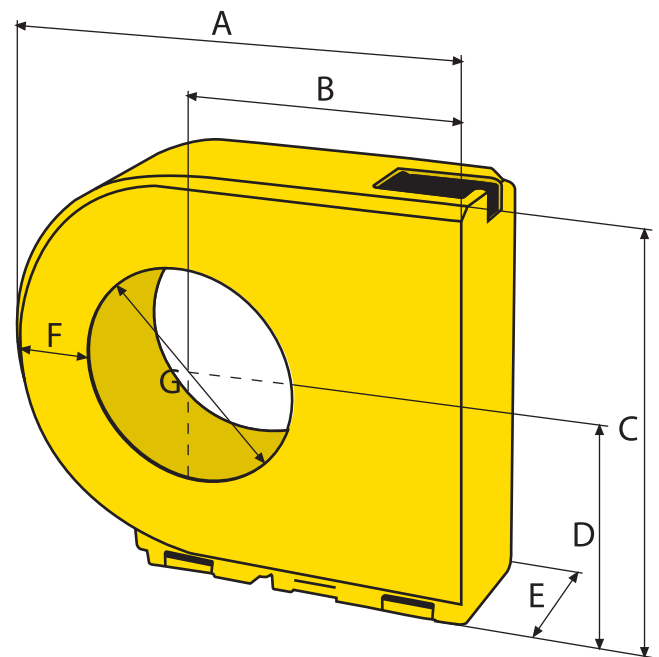
Dimension diagram

Dimensions

Type	A	B	C	D	E	F	G	Weight
W20	76.4	50	56.3	29.8	30	16.4	∅ 20	≤ 0.13 kg
W35	99.5	62	79.2	41.7	30	20	∅ 35	≤ 0.175 kg
W60	135	79	116.4	60.4	37	24	∅ 60	≤ 0.315 kg
W120	210	116.5	191.5	98	37	33.5	∅ 120	≤ 0.96 kg
W210	323	173	304.5	154.5	45	45	∅ 210	≤ 2.9 kg
W20-8000*	76.4	50	56.3	29.8	30	16.4	∅ 20	≤ 0.15 kg
W35-8000*	99.5	62	79.2	41.7	30	20	∅ 35	≤ 0.205 kg
W60-8000*	135	79	116.4	60.4	37	24	∅ 60	≤ 0.355 kg

Dimensions are given in mm

* For insulation fault locations systems of the EDS461/491 and EDS473/474 series

Mounting details

Screw mounting with mounting brackets: W20, W35, W60 and W20-8000, W35-8000, W60-8000

Snap-on mounting on DIN rail: for vertical or horizontal mounting: W20, W35, W60 und W20-8000, W35-8000, W60-8000

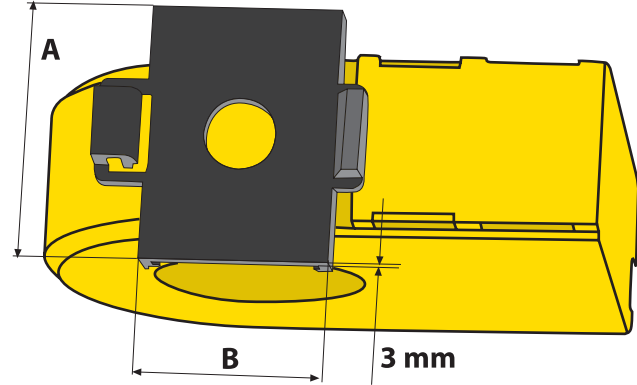
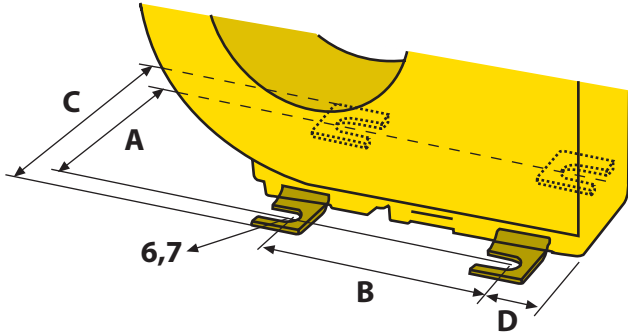

Screw mounting: W120, W210

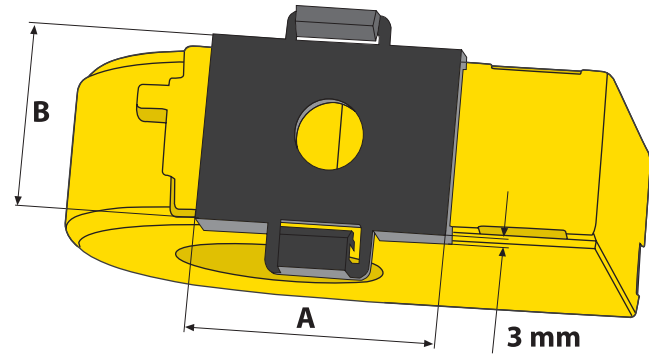
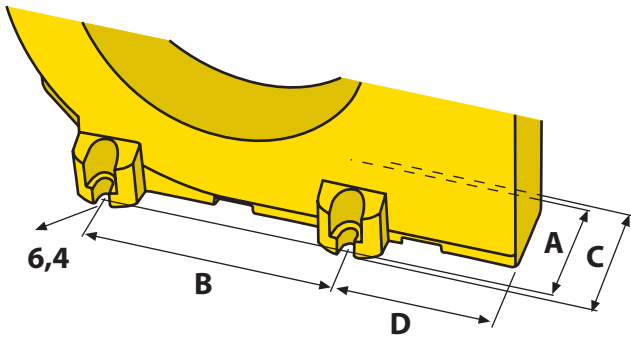

Dimensions screw mounting

Type	A	B	C	D
W20/W20-8000 (mounting with two mounting brackets, diagonally)	47	31.4	63	18.6
W35/W35-8000 (mounting with two mounting brackets, diagonally)	47	49.8	63	12.1
W60/W60-8000 (mounting with four mounting brackets)	54	66	70	17.7
W120 screw mounting	51	103	60.6	65
W210 screw mounting	59	180	68.6	83

Dimensions snap-on mounting

Type	A	B
W20/W20-8000	43.5	32
W35/W35-8000	43.5	32
W60/W60-8000	50	39

Dimensions are given in mm

Dimensions are given in mm

Selection list

Type	RCM420	RCM470	RCMS460/490	EDS460/490	EDS461/491	EDS470	EDS473	EDS474
W20	×	×	×	×	--	×	--	--
W35	×	×	×	×	--	×	--	--
W60	×	×	×	×	--	×	--	--
W120	×	×	×	×	--	×	--	--
W210	×	×	×	×	--	×	--	--
W20-8000	--	--	--	--	×	--	×	×
W35-8000	--	--	--	--	×	--	×	×
W60-8000	--	--	--	--	×	--	×	×