

## A-ISOMETER® IR5002

Insulation monitoring device for  
DC systems (IT)



A-ISOMETER® IR5002

### Device features

- Voltage range of the system being monitored DC 350...800 V
- 3-Voltmeter Method for fast detection of symmetrical and asymmetrical insulation faults
- Wide response range 5 Ω...100 kΩ
- Integrated voltage monitoring
- Two serial interfaces RS-232 and RS-485
- Linear analogue output 0...20 mA
- Three output alarm relays for insulation fault at L+, L- and system fault
- Large LC display
- Control via microcontroller
- Real-time clock
- Menu-driven handling
- Robust enclosure for wall mounting

### Approval



### Product description

The insulation monitoring device of the IR5002 series, continuously monitors the insulation resistance of unearthed DC systems to earth. The device is designed to signal a drop in insulation resistance below a minimum value.

### Application

Application in IT DC systems involving specific problems:

- Systems with low insulation resistances and high nominal voltages
- Systems with water-cooled components
- Heating systems with ionizing air
- Melting plants
- Extended systems

### Function

The A-ISOMETER® IR5002 complies with the requirements of DIN EN 61557-8: "Insulation monitoring devices for IT systems". The internal resistance has been adapted to the special applications for systems with low insulation resistance values. This standard deals with the construction, measurement technique, the test procedures and the safety aspects of insulation monitoring devices in IT systems. The application in IT AC systems, IT DC systems and IT AC systems with galvanically connected DC circuits is also dealt with.

IR5002 works according to a passive 3-voltmeter method. Different voltage values of the system being monitored are measured. In addition, comparative measurements of the internal resistor network are carried out in order to determine the correct insulation resistance of the system.

The results of the voltage measurements are digitalized by a 22-bit AD converter which is connected to the microcontroller via a serial bus.

Measuring data acquisition, processing, analysis and output is controlled by a microcontroller allowing the setting of different device parameters. The measured values can be transmitted to peripheral devices, e.g. computers or PLCs via serial interfaces. The device parameters are stored in a non-volatile EEPROM. The internal real-time clock allows appropriate assignment of the measured insulation resistance values.

The measuring circuit is isolated from the output circuits (relays, interfaces). That provides protection to both the IR5002 and the connected peripheral devices.

The IR5002 can be used as an independent device or in combination with the coupling device AG5002. The coupling device AG5002 is required when response values below 1000 Ω are to be set. The IR5002 automatically recognizes if a coupling device has been connected.

### Measuring principle

The IR5002 uses the measuring principle "3-Voltmeter Method" (3VM). This method allows symmetrical and asymmetrical insulation faults to be measured in IT DC systems. In combination with the microcontroller a fast, safe and exact measurement and evaluation can be realized.

Wiring diagram

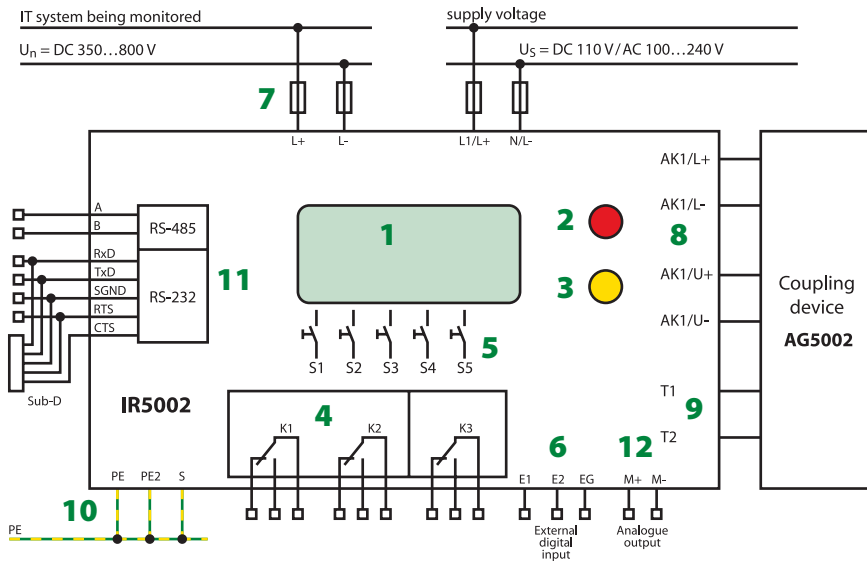

- 1 - LC display, 4 lines á 20 characters
- 2 - Alarm LED, red, Alarm L+
- 3 - Alarm LED, yellow, Alarm L
- 4 - Alarm relay Alarm L+, Alarm L- and system fault
- 5 - Function keys: UP key, DOWN key, RIGHT key, LEFT key, ENTER key
- 6 - Digital input
- 7 - Connection to the system being monitored
- 8 - Connection to the coupling device AG5002
- 9 - Temperature monitoring of the coupling device AG5002
- 10 - Connection monitoring and earth
- 11 - Outputs for RS-485 interface, RS-232 interface on terminal strip and a 9-pole SUB-D connector
- 12 - Analog outputs

Upper terminal box

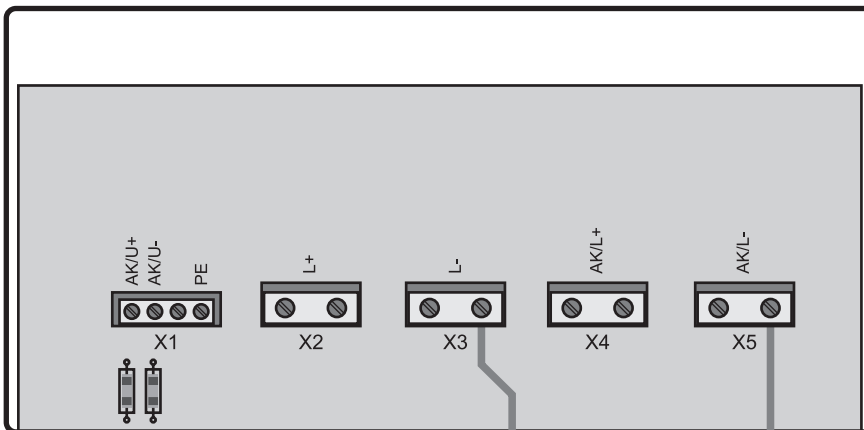

The upper terminal box is intended for the coupling of the measuring circuit to the system being monitored and the connection to the optional coupling device AG5002.

Lower terminal box

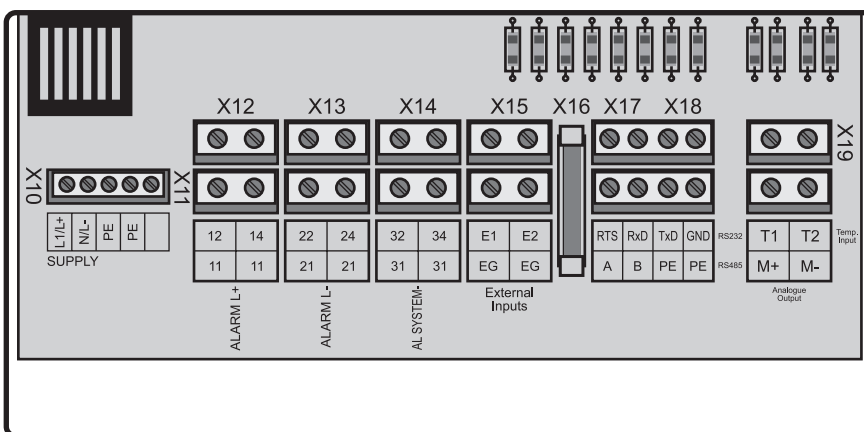

The lower terminal box contains the terminal strips X10...X19 which are intended for the connection of the supply voltage, PE-connections as well as all inputs and outputs.

## Technical data A-ISOMETER® IR5002

### Insulation coordination acc. to IEC 60664-1

Rated insulation voltage	DC 800 V
Rated impulse voltage/pollution degree	8 kV/3
Voltage test acc. to IEC 61010-1	4 kV

### System being monitored

Nominal system voltage $U_n$	DC 350...800 V
Operating range of $U_n$	DC 100...1100 V

### Supply voltage

Supply voltage $U_S$	AC 50...60 Hz 100...240 V
Operating range $U_S$ AC	0.9...1.1 $U_S$
Supply voltage $U_S$	DC 110 V
Operating range $U_S$ DC	0.8...1.2 $U_S$
Power consumption	≤ 30 W

### Response values

Response value $R_{ALARM}$	5 Ω...100 kΩ
(For response values < 1000 Ω the coupling device AG5002 has to be used)	
Limit value for alarm indication	350 oder 100 V
Permissible system leakage capacitance	≤ 10 μF

### Response times

Delay-Time	0...100 s
Window-Time	0...300 s

### Measuring circuit

Internal DC resistance $R_i$	500 kΩ
Internal DC resistance $R_i$ with AG5000	5 kΩ

### Relay outputs

Contact circuits	
Switching elements	3 changeover contacts
Contact class in accordance with DIN IEC 60255-0-20	IIB
Rated contact voltage	AC 250 V/DC 300 V
Electrical service life, numbers of cycles	12000
Making capacity	AC/DC 5 A
Breaking capacity	
at AC 230 V and $\cos \phi = 0.4$	AC 2 A
at DC 220 V und $L/R = .0.04$ s	DC 0.2 A
Operating principle, K1 and K2 switchable	N/O or N/C operation
Factory setting of K1 and K2	N/O operation
Operating principle K3	N/C operation

### Interfaces

Serial interface	RS-232 and RS-485
------------------	-------------------

### Outputs

Analogue output M+/M-*	0...20 mA, linear
------------------------	-------------------

### Inputs

Digital input 1 (E1/EG)	switchable DC 24 V or DC 5 V
Digital input 2 (E1/EG)	currently no function assigned

### Environment/EMC

EMC	acc. to 61326
Operating temperature	-25 °C...+55 °C
Climatic categories acc. to IEC 60721:	
Stationary use (IEC 60721-3-3) (except condensation and formation of ice)	3K5
Transport (IEC 60721-3-2) (except condensation and formation of ice)	2K3
Storage (IEC 60721-3-1) (except condensation and formation of ice)	1K4
Classification of mechanical conditions acc. to IEC 60721:	
Stationary use (IEC 60721-3-3)	3M4
Transport (IEC 60721-3-2)	2M2
Storage (IEC 60721-3-1)	1M3

### Connection

Connection	Flat terminals with self-lifting clamp washers
rigid/flexible/AWG	0.2...4/0.2...2.5 mm <sup>2</sup> / AWG 24...12

### General data

Operating mode	continuous operation
Mounting	any position
Degree of protection	IP65
Wire cross section	
single wire/flexible	0.2...4 mm <sup>2</sup> /0.2...2.5 mm <sup>2</sup> (AWG 24 - 12)
Enclosure	19" enclosure 30 TE/4 HE for wall mounting
Operating manual	TGH1360

\* see diagram current output IR5002

## Ordering information

Type	Art. No.
IR5002	B 9105 9010
AG5002	B 9802 9009

## Diagram current output IR5002

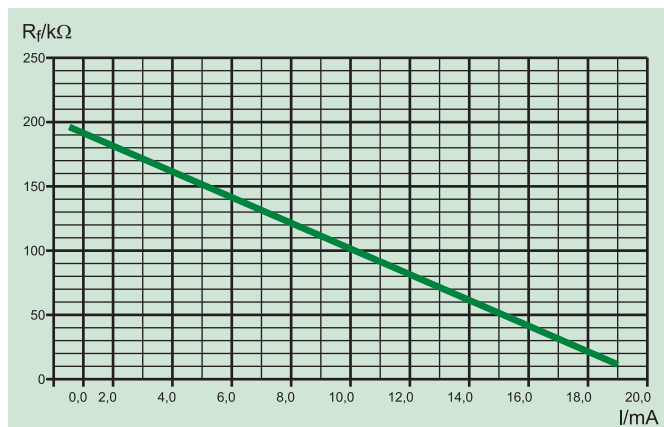

**Dimension diagrams A-ISOMETER® IR5002**

Dimensions are given in mm

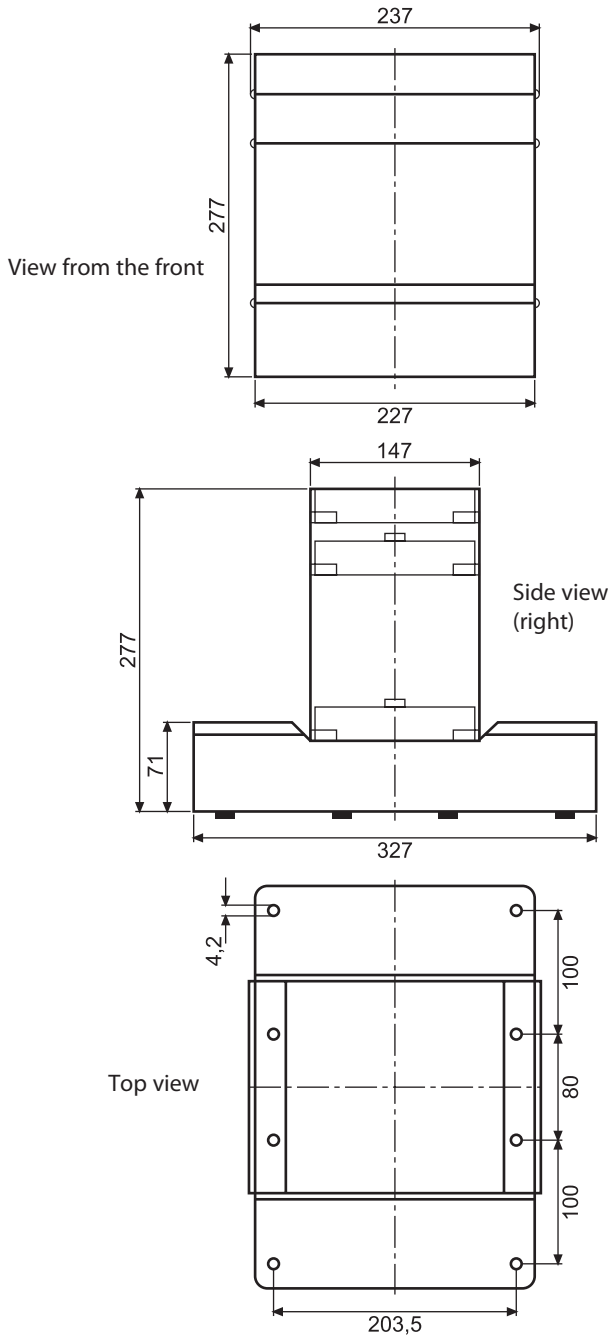

**Dimension diagrams coupling device AG5002**

Dimensions are given in mm

