

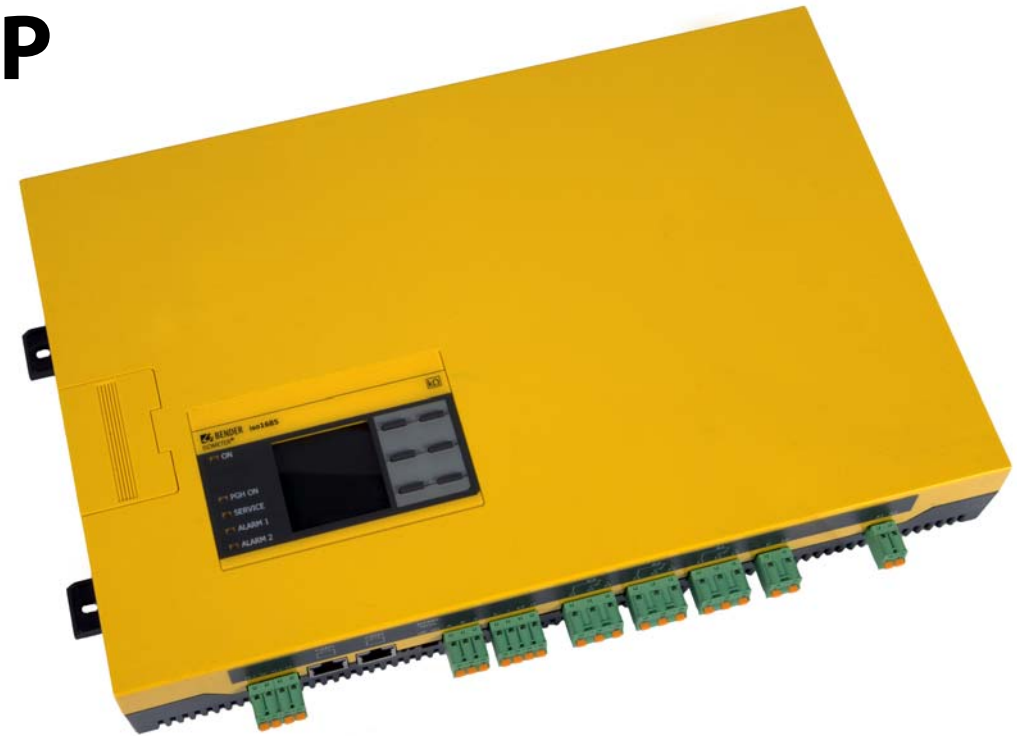

ISOMETER® iso1685DP

AC/DC

Insulation monitoring device for unearthed
AC, AC/DC and DC power supplies (IT systems)
up to AC 1000 V / DC 1500 V
Software version D484 V2.xx
D485 V1.xx





Bender GmbH & Co. KG

Postfach 1161 • 35301 Gruenberg • Germany
Londorfer Straße 65 • 35305 Gruenberg • Germany

Tel.: +49 6401 807-0
Fax: +49 6401 807-259

E-Mail: info@bender.de
Web: www.bender.de

Customer service
Service-Hotline: 0700-BenderHelp (Telephone and Fax)
Carl-Benz-Straße 8 • 35305 Grünberg • Germany

Tel.: +49 6401 807-760
Fax: +49 6401 807-629

E-Mail: info@bender-service.com

© Bender GmbH & Co. KG
All rights reserved.
Reproduction only with permission
of the publisher.
Subject to change.

1. Important information	6	4. Device overview	14
1.1 How to use this manual	6	4.1 Dimensions	14
1.2 Technical support	6	4.2 Connections	15
1.2.1 First level support	6	4.3 Display and operating elements	16
1.2.2 Repair service	6	4.3.1 Display elements	16
1.2.3 Field service	7	4.3.2 Device buttons	16
1.3 Training courses	7	4.3.3 Operating elements in the service lid	16
1.4 Delivery conditions	7	5. Installation and connection	17
1.5 Storage	7	5.1 Installation	17
1.6 Disposal	7	5.2 Connection	17
2. Safety instructions	8	5.2.1 Connection requirements	17
2.1 General safety instructions	8	5.2.2 Step-by-step connection of the ISOMETER®	18
2.2 Work activities on electrical installations	8	5.2.3 Connecting the EDS to the ISOMETER®	18
2.3 Device-specific safety information	8	5.3 Connection to an AC system	19
2.4 Address setting and termination	9	5.4 Connection example of the ISOMETER® with an insulation fault locator (EDS440/441-L) to a 3AC system	20
2.5 Intended use	9	5.5 Connection example of the ISOMETER® with an insulation fault locator (EDS460) to an AC system	21
3. Function	10	6. Commissioning	22
3.1 Features	10	6.1 Commissioning flow chart insulation fault monitoring	22
3.2 Product description	10	6.2 Commissioning flow chart insulation fault location	22
3.3 Function description	10	6.3 Initial commissioning	23
3.3.1 Insulation monitoring	11	6.3.1 Setting the language	23
3.3.2 Insulation fault location	11	6.3.2 Setting date and time	23
3.3.3 Assignment of the alarm relays K1, K2, K3	11	6.3.3 Setting the profile	23
3.3.4 Deactivating the device	12	6.3.4 Setting response value Ran1 for Alarm 1	23
3.3.5 Measured value transmission	12	6.3.5 Setting response value Ran2 for Alarm 2	24
3.4 History memory	12	6.3.6 Setting EDS mode	24
3.5 Self test	12	6.3.7 Set the EDS current	24
3.5.1 Self test after connection to the supply voltage	12	6.3.8 TEST	24
3.5.2 Automatic self test	13		
3.5.3 Manual self test	13		

6.4	Recommissioning	24
6.5	Commissioning EDS	25
7.	Display	26
7.1	Standard display.....	26
7.2	Fault indication (active).....	26
7.3	Fault indication (inactive).....	27
7.4	Acknowledging a fault message	27
7.5	Data - isoGraph.....	28
7.6	History memory	28
7.7	Insulation fault location.....	28
8.	Menu	29
8.1	Overview of the device menu	29
8.2	Operation and Navigation	29
9.	Settings.....	30
9.1	(1.0) Alarm settings.....	30
9.1	(1.1) Insulation alarm	30
9.1	(1.1.1) Alarm 1	30
9.1	(1.1.2) Alarm 2	30
9.1	(1.2) Profile.....	30
9.1	(1.3) Fault memory	30
9.1	(1.4) Device	31
9.1	(1.5) Coupling monitoring	31
9.1	(1.6) Inputs.....	31
9.1	(1.6.1) Digital 1.....	31
9.1	(1.6.1.1) Mode	31
9.1	(1.6.1.2) t(on)	31
9.1	(1.6.1.3) t(off)	31
9.1	(1.6.1.4) Function	32
9.1	(1.6.2) Digital 2.....	32
9.1	(1.7) Outputs.....	32
9.1	(1.7.1) Relay 1	32
9.1	(1.7.1.1) TEST	32
9.1	(1.7.1.2) Operating mode	32
9.1	(1.7.2) Relay 2	32

9.1	(1.7.3) Buzzer.....	32
9.1	(1.7.3.1) TEST.....	32
9.1	(1.7.3.2) Function 1.....	33
9.1	(1.7.3.3) Function 2.....	33
9.1	(2.0) EDS (insulation fault location)	33
9.1	(2.1) Mode.....	33
9.1	(2.2) Current.....	34
9.1	(3.0) Data measured values	34
9.1	(4.0) Control	34
9.1	(5.0) History	34
9.1	(6.0) Device settings	34
9.1	(6.1) Language.....	35
9.1	(6.2) Clock	35
9.1	(6.2.1) Time	35
9.1	(6.2.2) Format (time).....	35
9.1	(6.2.3) Summer time.....	35
9.1	(6.2.4) Date.....	35
9.1	(6.2.5) Format (date).....	35
9.1	(6.3) Interface.....	36
9.1	(6.3.1) BMS.....	36
9.1	(6.3.1.1) BMS address.....	36
9.1	(6.4) Display	36
9.1	(6.4.1) Brightness.....	36
9.1	(6.5) Password.....	36
9.1	(6.5.1) Password	36
9.1	(6.5.2) Status	36
9.1	(6.6) Commissioning	36
9.1	(6.7) Service	36
9.1	(7.0) Info	36
9.2	Factory settings.....	37

10. Device communication via the BMS bus	38
10.1 RS-485 interface with BMS protocol	38
10.2 Topology RS-485 network	38
10.3 BMS protocol	39
10.4 BMS master	39
10.5 Commissioning of an RS-485 network with BMS protocol	39
10.6 Setting BMS address	39
10.7 Alarm and operating messages via the BMS bus	40
10.7.1 Alarm messages	40
10.7.2 Operating messages	40
10.7.3 Resetting error messages	40
10.7.4 Error codes	41
11. Insulation fault location	42
11.1 General description	42
11.2 Required settings for insulation fault location	42
11.3 Indication on the display	42
11.4 Starting and stopping the insulation fault location	42
12. Device profiles	43
13. Alarm messages	44
14. Diagrams	45
14.1 Response time profile Power circuits	45
14.2 Response time profile High capacitance	46
14.3 Response time profile Inverter > 10 Hz	47
14.4 Response time profile Inverter < 10 Hz	48
14.5 Response time profile Fast 2000 μ F	49
14.6 Leakage capacitance	50

15. Technical data	51
15.1 Tabular data iso1685DP	51
15.2 Standards and certifications	52
15.3 Ordering details	52

1.1 How to use this manual



This manual is intended for **qualified personnel** working in electrical engineering and electronics!

Always keep this manual within easy reach for future reference.

To make it easier for you to understand and revisit certain sections in this manual, we have used symbols to identify important instructions and information. The meaning of these symbols is explained below:



This signal word indicates that there is a **high risk of danger** that will result in **electrocution** or **serious injury** if not avoided.



This signal word indicates a **medium risk of danger** that can lead to **death** or **serious injury** if not avoided.



This signal word indicates a **low-level risk** that can result in **minor** or **moderate injury** or **damage to property** if not avoided.



This symbol denotes information intended to assist the user in making **optimum use** of the product.

1.2 Technical support

For commissioning and troubleshooting Bender offers you:

1.2.1 First level support

Technical support by phone or e-mail for all Bender products

- Questions concerning specific customer applications
- Commissioning
- Troubleshooting

Telephone: +49 6401 807-760*

Fax: +49 6401 807-259

In Germany only: 0700BenderHelp (Tel. and Fax)

E-mail: support@bender-service.de

1.2.2 Repair service

Repair, calibration, update and replacement service for Bender products

- Repairing, calibrating, testing and analysing Bender products
- Hardware and software update for Bender devices
- Delivery of replacement devices in the event of faulty or incorrectly delivered Bender devices
- Extended guarantee for Bender devices, which includes an in-house repair service or replacement devices at no extra cost

Telephone: +49 6401 807-780** (technical issues)

+49 6401 807-784**, -785** (sales)

Fax: +49 6401 807-789

E-mail: repair@bender-service.de

Please send the devices for **repair** to the following address:

Bender GmbH, Repair-Service,
Londorfer Strasse 65,
35305 Grünberg

1.2.3 Field service

On-site service for all Bender products

- Commissioning, parameter setting, maintenance, troubleshooting for Bender products
- Analysis of the electrical installation in the building (power quality test, EMC test, thermography)
- Training courses for customers

Telephone: +49 6401 807-752**, -762 **(technical issues)
+49 6401 807-753** (sales)
Fax: +49 6401 807-759
E-mail: fieldservice@bender-service.de
Internet: www.bender-de.com

*Available from 7.00 a.m. to 8.00 p.m. 365 days a year (CET/UTC+1)

**Mo-Thu 7.00 a.m. - 8.00 p.m., Fr 7.00 a.m. - 13.00 p.m.

1.3 Training courses

Bender is happy to provide training regarding the use of test equipment.

The dates of training courses and workshops can be found on the Internet at www.bender-de.com -> Know-how -> Seminars.

1.4 Delivery conditions

Bender sale and delivery conditions apply.

For software products the "Softwareklausel zur Überlassung von Standard-Software als Teil von Lieferungen, Ergänzung und Änderung der Allgemeinen Lieferbedingungen für Erzeugnisse und Leistungen der Elektroindustrie" (software clause in respect of the licensing of standard software as part of deliveries, modifications and changes to general delivery conditions for products and services in the electrical industry) set out by the ZVEI (Zentralverband Elektrotechnik- und Elektronikindustrie e. V.) (German Electrical and Electronic Manufacturer's Association) also applies.

Sale and delivery conditions can be obtained from Bender in printed or electronic format.

1.5 Storage

The devices must only be stored in areas where they are protected from dust, damp, and spray and dripping water, and in which the specified storage temperatures can be ensured.

1.6 Disposal

Abide by the national regulations and laws governing the disposal of this device. Ask your supplier if you are not sure how to dispose of the old equipment.

The directive on waste electrical and electronic equipment (WEEE directive) and the directive on the restriction of certain hazardous substances in electrical and electronic equipment (RoHS directive) apply in the European Community. In Germany, these policies are implemented through the "Electrical and Electronic Equipment Act" (ElektroG). According to this, the following applies:

- Electrical and electronic equipment are not part of household waste.
- Batteries and accumulators are not part of household waste and must be disposed of in accordance with the regulations.
- Old electrical and electronic equipment from users other than private households which was introduced to the market after 13 August 2005 must be taken back by the manufacturer and disposed of properly.

For more information on the disposal of Bender devices, refer to our homepage at www.bender-de.com -> Service & support.

2.1 General safety instructions

Part of the device documentation in addition to this manual is the enclosed "Safety instructions for Bender products".

2.2 Work activities on electrical installations.



Only **qualified personnel** are permitted to carry out the work necessary to install, commission and run a device or system.



Risk of electrocution due to electric shock!

Touching live parts of the system carries the risk of:

- An electric shock
- Damage to the electrical installation
- Destruction of the device

Before installing and connecting the device, make sure that the installation has been de-energised. Observe the rules for working on electrical installations.

If the device is used outside the Federal Republic of Germany, the applicable local standards and regulations must be complied with. The European standard EN 50110 can be used as a guide.

2.3 Device-specific safety information



Danger as a result of excessive locating current or excessive locating voltage!

An excessive locating current of the internal locating current injector may damage sensitive loads (e.g. control circuits) or trigger unwanted switching operations. Select a low locating current for these systems. In case of doubt, please contact our service department.



Risk of electric shock!

When opening the device, you may come into contact with live parts. Switch off the mains voltage before opening the device!



Make sure that the basic settings meet the requirements of the IT system. Persons without the required expertise, in particular children, must not have access to or contact with the ISOMETER®.



Make sure that the operating voltage is correct!

Prior to insulation and voltage tests, the ISOMETER® must be disconnected from the IT system for the duration of the test. In order to check the correct connection of the device, a functional test has to be carried out before starting the system.



In the event of an alarm message of the ISOMETER®, the insulation fault should be eliminated as quickly as possible.



If the ISOMETER® is installed inside a control cabinet, the insulation fault message must be audible and/or visible to attract attention.



When using ISOMETER®s in IT systems, make sure that only one active ISOMETER® is connected in each interconnected system. If IT systems are interconnected via coupling switches, make sure that ISOMETER®s not currently used are disconnected from the IT system and deactivated. IT systems coupled via diodes or capacitances may also influence the insulation monitoring process so that a central control of the different ISOMETER®s is required.

**Prevent measurement errors!**

When a monitored IT system contains galvanically coupled DC circuits, an insulation fault can only be detected correctly if the rectifier valves (e.g. rectifier diode, thyristors, IGBTs, frequency inverters, ...) carry a minimum current of > 10 mA.

**Unspecified frequency range**

When connecting to an IT system with frequency components below the specified frequency range, the response times and response values may differ from the indicated technical data. However, depending on the application and the selected measurement method, continuous insulation monitoring is also possible in this frequency range.

There is no influence on the insulation monitoring for IT systems with frequency components above the specified frequency range, e.g. within the range of typical switching frequencies of frequency inverters (2...20 kHz).

2.4 Address setting and termination

Correct address setting and termination is essential for proper functioning of the iso1685... series insulation monitoring device.

**CAUTION****Risk of bus errors!**

Double assignment of addresses on the respective BMS busses can cause serious malfunctions.

Ensure correct address setting and termination of the device!

2.5 Intended use

Only **qualified personnel** are permitted to carry out the work necessary to install, commission and run a device or system.

The device is used for monitoring the insulation resistance in large power supply systems designed as IT systems. The specific measurement technique (AMP⁺) monitors the insulation resistance also in installations where extremely high system leakage capacitances to earth exist due to interference suppression methods. The adjustment also to high system leakage capacitances occurs automatically.

The device generates locating current pulses required for insulation fault location. That allows the localisation of the insulation fault using permanently installed or mobile insulation fault locators.

Intended use also implies:

- The observation of all information in the operating manual
- Compliance with test intervals

In order to meet the requirements of applicable standards, the equipment must be adjusted to local equipment and operating conditions by means of customised parameter settings. Please heed the limits of the range of application indicated in the technical data.

Any other use than that described in this manual is regarded as improper.

3.1 Features

- Insulation monitoring in extensive unearthed power supply systems up to AC 1000 V/DC 1500 V
- Measurement of low-resistance insulation faults
- Separately adjustable response values R_{an1} (alarm 1) and R_{an2} (alarm 2) (both 200 Ω ...1 M Ω)
- Automatic adjustment to high system leakage capacitances up to 2000 μ F, selectable range
- Integrated locating current injector up to 50 mA
- Device self test with automatic message in the event of a fault
- Alarm relays separately adjustable for insulation fault 1, insulation fault 2 and device error
- RS-485 interface (BMS bus), e.g. to control the insulation fault location.
- The device does not have a master function. It can only act as backup master.
- The integrated μ SD card slot cannot be used. The device does not store any data on the μ SD card.

3.2 Product description

The ISOMETER® is an insulation monitoring device for IT systems in accordance with IEC 61557-8 and IEC 61557-9. It is applicable for use in AC/DC systems.

3.3 Function description

The insulation monitoring device ISOMETER® iso1685DP-425 continuously monitors the entire insulation resistance of an IT system during operation and triggers an alarm when the value falls below a preset response value. To obtain a measurement, the device has to be connected between the IT system (unearthed system) and the protective earth conductor (PE). A measuring current in the μ A range is superimposed onto the system which is recorded and evaluated by a microcontrolled measuring circuit. The measuring time depends on the selected measurement methods, the system leakage capacitance, the insulation resistance and possible system-related disturbances. In addition, it features an integrated locating current injector for insulation fault location.

The response values and other parameters are set using a commissioning wizard or via different setup menus using the device buttons and a high-resolution graphic LC display. The selected settings are stored in a permanent fail-safe memory. Different languages can be selected for the setup menus and the messages indicated on the display.

The device utilises a clock for storing fault messages and events in a history memory with time and date stamp. The settings can be protected against unauthorised modifications by a password.

The ISOMETER® cannot take over the master function. If there is no master in the system, the device can act as a backup master and communicate with the slaves in the system.

3.3.1 Insulation monitoring

For insulation monitoring, a pulsating AC measuring voltage is superimposed onto the IT system. The measuring pulse consists of positive and negative rectangular impulses of the same amplitude. The period duration depends on the system leakage capacitances in each case and the insulation resistances of the system to be monitored.



Abb. 3.1: Pulse sequence of the measuring voltage for insulation fault monitoring

An insulation fault between the IT system and earth closes the measuring circuit. If the insulation resistance between system and earth falls below the set response values R_{an1} and R_{an2} (response value R_{an1} can be set equal or higher than R_{an2}), the associated alarm relays K1 (11, 12, 14) or K2 (21, 22, 24) switch. Detected insulation faults are signalled to other bus devices via the BMS bus. In addition, the alarm LEDs Alarm 1 or Alarm 2 light up.

3.3.2 Insulation fault location

For insulation fault location, a suitable locating current is superimposed onto the faulty IT system with which insulation fault locators of the EDS... series can locate insulation faults. The ISOMETER® utilises an internal locating current injector with $I_L \leq 50$ mA DC.

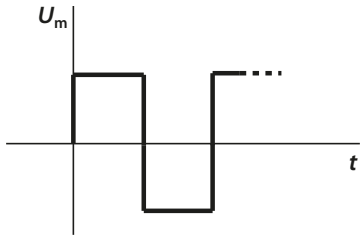

Abb. 3.2: Pulse sequence of the internal locating current injector for insulation fault location

If the EDS function is activated, the ISOMETER® starts the insulation fault location after the value has fallen below the response values R_{an1} and R_{an2} . When starting the insulation fault location, the LED "PGH on" signals the locating current pulse.

When permanently installed insulation fault locators (with master capability) such as EDS460-D or EDS490-D are used, control and synchronisation of the locating current injector is carried out via the BMS master. For this purpose, the ISOMETER® and the insulation fault locator have to communicate with the insulation fault locator via the BMS bus.

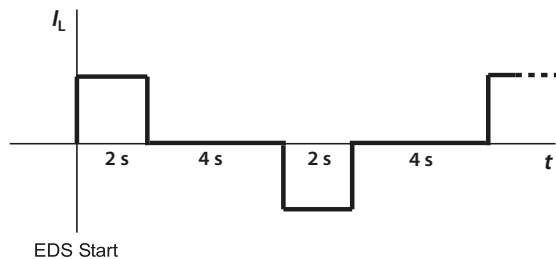

During the insulation fault location process, the function of insulation resistance measurement is deactivated and the coupling is disconnected from the mains.

Parameterisation of the insulation fault location

By means of the BMS gateway, e.g. the COM460IP or the terminal program, different modes can be selected via the BMS bus:

- off:
Switch off insulation fault location
- auto (automatic):
Factory setting = Insulation fault location and pause, alternately 5 minutes each. During each pause, the device automatically switches to insulation fault measurement
- on (permanent):
The locating current required for insulation fault location is permanently supplied to the device

In addition, the value of the locating current required for insulation fault location can be set to 1...50 mA via BMS.

3.3.3 Assignment of the alarm relays K1, K2, K3

K1 switches when the value falls below the alarm response value R_{an1} (insulation resistance).

K2 switches when the value falls below the alarm response value R_{an2} (insulation resistance).

K3 switches in the event of a device error or a connection fault.

3.3.4 Deactivating the device

When the device is deactivated, the coupling unit of the device is galvanically isolated from the system being monitored.

The device does not measure the insulation resistance, the message Device inactive appears on the display. The IT system is NOT being monitored!

The device uncouples itself from the system to be monitored through an internal system isolating switch.

Activation or deactivation is done via

- a digital input
- the menu item Alarm settings
- the BMS bus

The standby mode of the ISOMETER®, for example, enables application in coupled systems, since in interconnected systems only one insulation monitoring device is allowed to be connected in each system.

3.3.5 Measured value transmission

All recorded measured values, operating messages and alarms are made available via the BMS bus.

3.4 History memory

All warnings, alarms and device errors are stored in the internal history memory with date and time stamp. The time the event started, the time of acknowledgement and the end of the event are recorded. The history memory can be called up and reset via the device menu (see "History" on page 34).

3.5 Self test

3.5.1 Self test after connection to the supply voltage

Once connected to the supply voltage, all internal measurement functions, the components of the process control such as data and parameter memory as well as the connections to earth are checked. The self test is completed after approx. 60 s. Afterwards, the normal measurement mode begins.

If a device error or a connection fault is detected, the corresponding alarm will be indicated in the display as well as via the alarm relay K3 (31-32-34). This relay continuously operates in N/C operation, i.e. it de-energises even in case of a complete device failure.

During this self test, when the device is being started, the alarm relays are not switched.

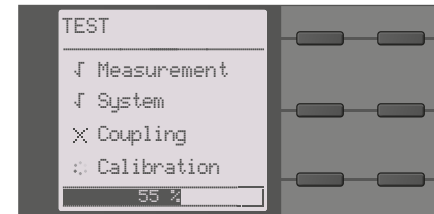

The test has been run and the result was positive.



The test has been run and the result was negative.



The test is running.

3.5.2 Automatic self test

All supply voltages are continuously monitored. The following tests are continuously carried out in the background:

- Connection E-KE
- Temperature monitoring of coupling and locating current injector

A self test is automatically run at 24-hour intervals.

During the automatic self test, the alarm relays K1 (11-12-14) and K2 (21-22-24) are **not** switched. K3 **won't** be switched either.

3.5.3 Manual self test

The self test is started via the Test button of the ISOMETER®.

The following tests are only carried out in the manual self test mode:

- Internal Flash
- CPU register
- Watchdogs
- Oscillator
- Restart of the device including re-initialisation and recalibration
- Connection monitoring system

During the manual self test, all alarm relays are switched.

4.1 Dimensions

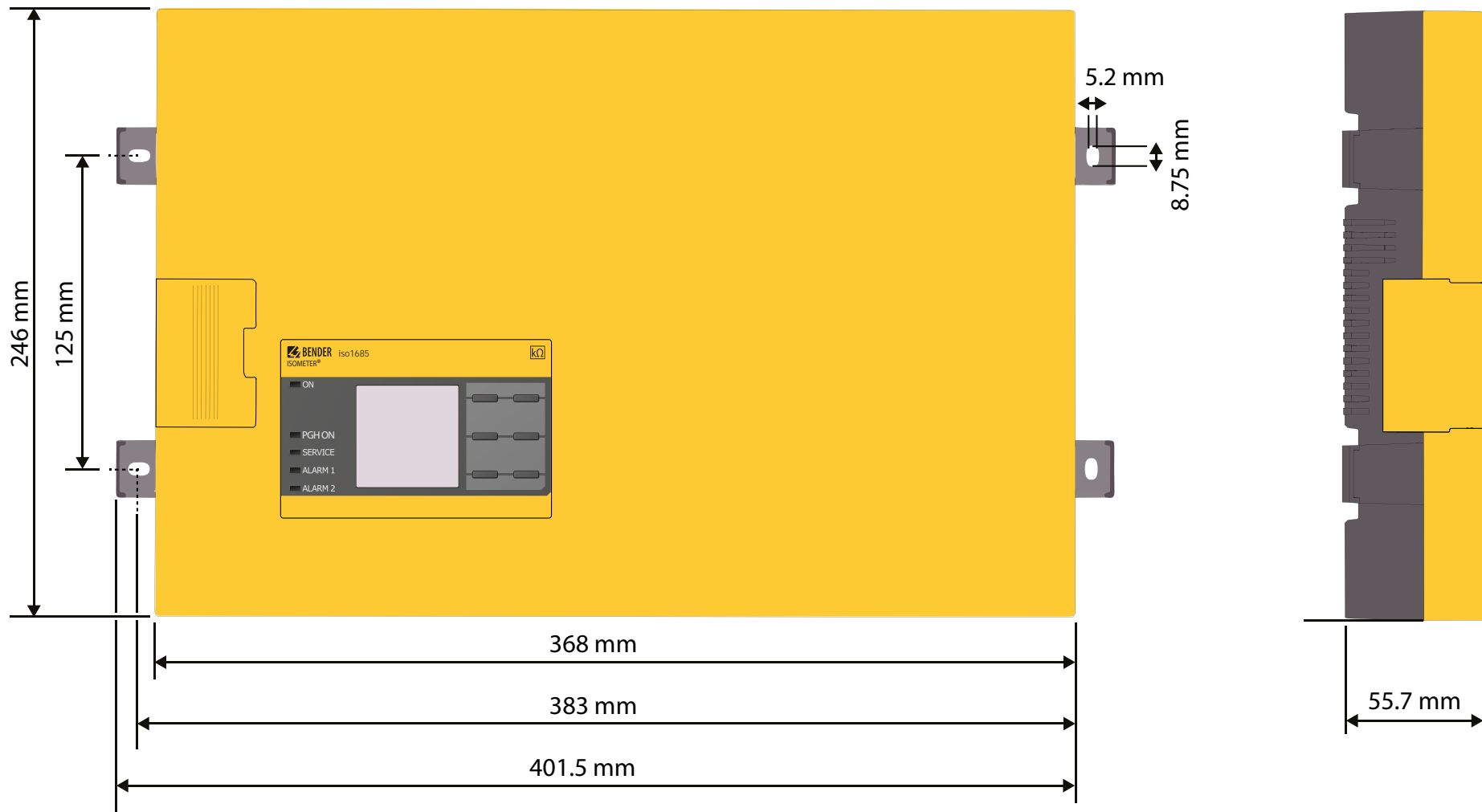

4.2 Connections

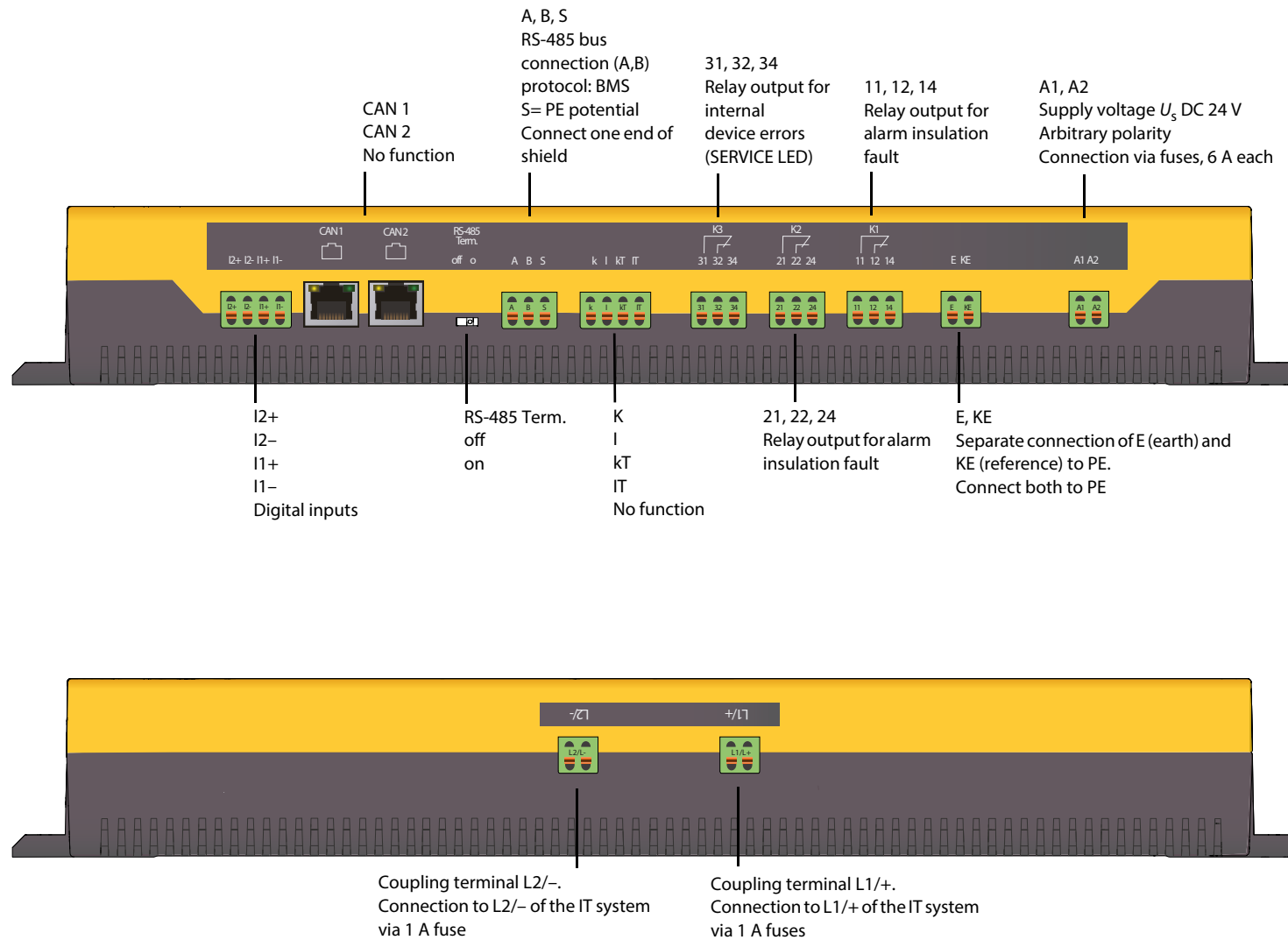

4.3 Display and operating elements

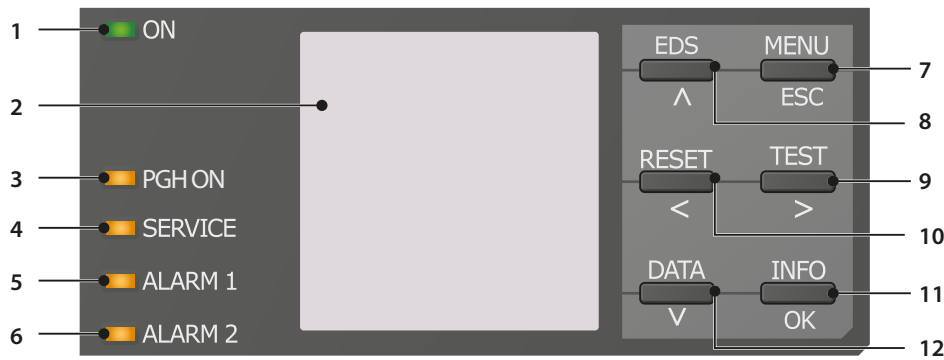

4.3.1 Display elements

1	ON (green)	The operation indicator lights continuously.
2		The device display shows information regarding the device and the measurements. Further information is available in the chapter "Display" ab Seite 26 .
3	PGH ON (yellow)	The LED "PGH ON" flashes during insulation fault location. It indicates that the locating current for the insulation fault location is generated.
4	SERVICE (yellow)	When a device error is detected, the SERVICE LED lights. If the LED stays lit, please check the error code list on Seite 38 .
5	ALARM 1 (yellow)	Insulation fault 1 (prewarning): The "ALARM 1" LED lights continuously when the insulation resistance falls below the response value 1, $R_F < R_{an1}$ Flashes: Connection fault, check earth and system (L1/+, L2/-)
6	ALARM 2 (yellow)	Insulation fault 2 (alarm): The "ALARM 2" LED lights continuously when the insulation resistance falls below the response value 2, $R_F < R_{an2}$ Flashes: Connection fault, check earth and system (L1/+, L2/-)

4.3.2 Device buttons

You can adjust the device settings in the respective menu using the menu buttons. Depending on the menu entry, one of the options displayed below is assigned to the buttons.

7	MENU	Opens the device menu.
7	ESC	Cancels the current process or navigates one step back in the device menu.
8	EDS	Opens the EDS menu.
8	∧	Navigates up in a list or increases a value.
9	TEST	Starts the device self test.
9	>	Navigates forwards (e.g. to the next setting step) or selects a parameter.
10	RESET	Resets alarms.
10	<	Navigates backwards (e.g. to the previous setting step) or selects a parameter.
11	INFO	Shows information.
11	OK	Confirms an action or a selection.
12	DATA	Indicates data and values.
12	∨	Navigates down in a list or reduces a value.

4.3.3 Operating elements in the service lid

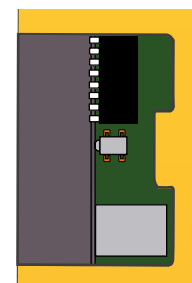

Operating elements	Function
DIP switch (SS8103)	No function
Button (ST6101)	Alarm reset
Memory card (SD Card)	No function

5.1 Installation

Install the device using four M5 screws, refer also to the dimension diagram where the drilling holes are illustrated (see "Dimensions" on page 14). Install the device so that it is in a vertical position with the system coupling (L1/+, L2/-) positioned at the top when it is being operated.

5.2 Connection

5.2.1 Connection requirements



Only **qualified personnel** are permitted to carry out the work necessary to install, commission and run a device or system.



DANGER

Risk of electrocution due to electric shock!

Touching live parts of the system carries the risk of:

- An electric shock
- Damage to the electrical installation
- Destruction of the device

Before installing and connecting the device, make sure that the installation has been de-energised. Observe the rules for working on electrical installations.



WARNING

Risk of injury from sharp-edged terminals!

Risk of lacerations. Touch the enclosure and the terminals with due care.



CAUTION

Risk of property damage due to unprofessional installation!

If more than one insulation monitoring device is connected to a conductively connected system, the system can be damaged. If several devices are connected, the device does not function and does not signal insulation faults. Make sure that only one insulation monitoring device is connected in each conductively connected system.



CAUTION

This signal word indicates a **low-level risk** that can result in **minor or moderate injury or damage to property** if not avoided.



Ensure disconnection from the IT system!

When insulation or voltage tests are to be carried out, the device must be isolated from the system for the test period. Otherwise the device may be damaged.



Check proper connection!

Prior to commissioning of the installation, check that the device has been properly connected and check the device functions. Perform a functional test using an earth fault via a suitable resistance.



All terminals are pluggable push-wire terminals. Solid connecting wires can be directly plugged in. For connection of flexible cables, the push-wire terminals must be pushed open by pressing the corresponding orange interlocking mechanism with a flat-head screwdriver.

5.2.2 Step-by-step connection of the ISOMETER®

Connect the device according to the wiring diagram.

Proceed as follows:

1. Connect terminal E and KE to earth (PE)
2. Connect terminal A and B to the BMS bus
3. Connect terminal S to the bus conductor shield (only at one end of the conductor)
4. Connect terminal L1/+ to L1 of the system to be monitored
5. Connect terminal L2/- to L2 of the system to be monitored



The coupling terminals L1/+ and L2/- are locked. To unplug the terminals, the orange sliders must be slid towards the front (towards the device) to unlock the terminal. Now the terminal can be unplugged.

6. Connect terminal A1/A2 to the supply voltage U_s
7. Connect alarm outputs 11/12/14, 21/22/24 and 31/32/34.

5.2.3 Connecting the EDS to the ISOMETER®



Risk of malfunctions due to excessive locating current on sensitive system parts!

The locating current flowing between the IT system and earth can cause controller faults in sensitive parts of the system, such as the PLC or relay. Ensure that the level of the locating current is compatible with the system to be monitored.



Risk of incorrect measurement

The supplied locating current may influence other connected insulation fault location systems. If they measure the injected locating current, the measurement might be incorrect.



Insulation monitoring is deactivated while the insulation fault location is active.

5.3 Connection to an AC system

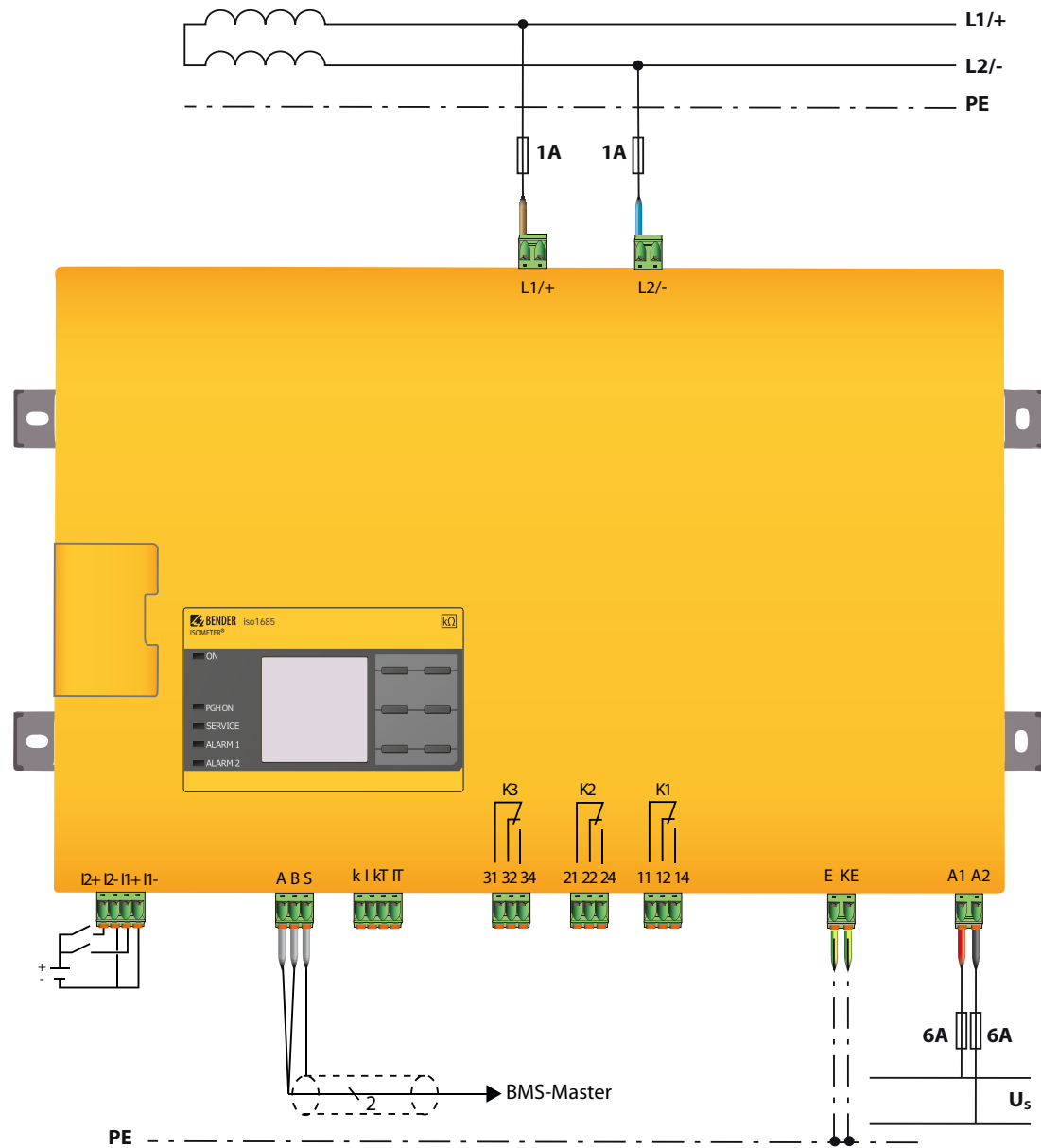

5.4 Connection example of the ISOMETER® with an insulation fault locator (EDS440/441-L) to a 3AC system

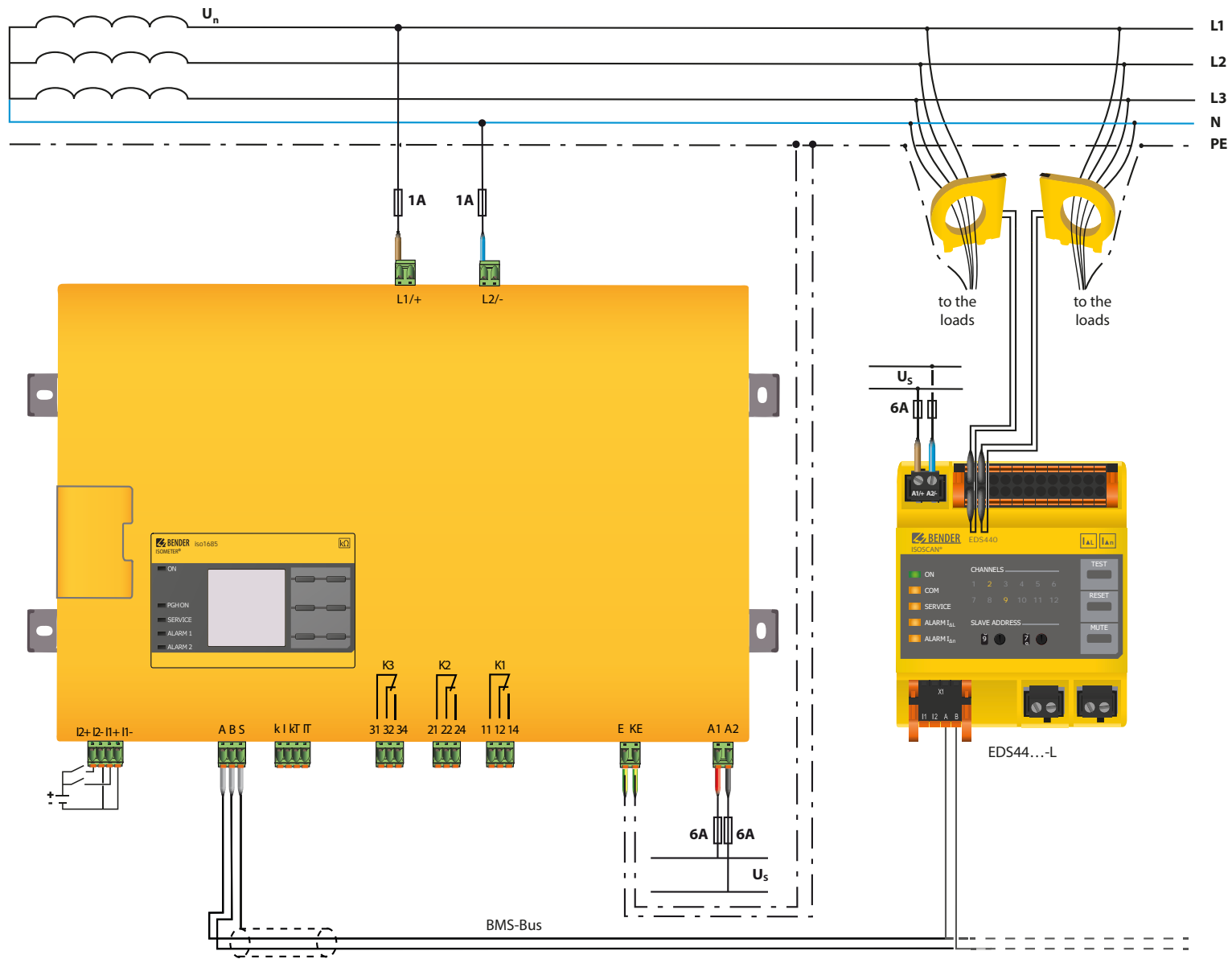

5.5 Connection example of the ISOMETER® with an insulation fault locator (EDS460) to an AC system

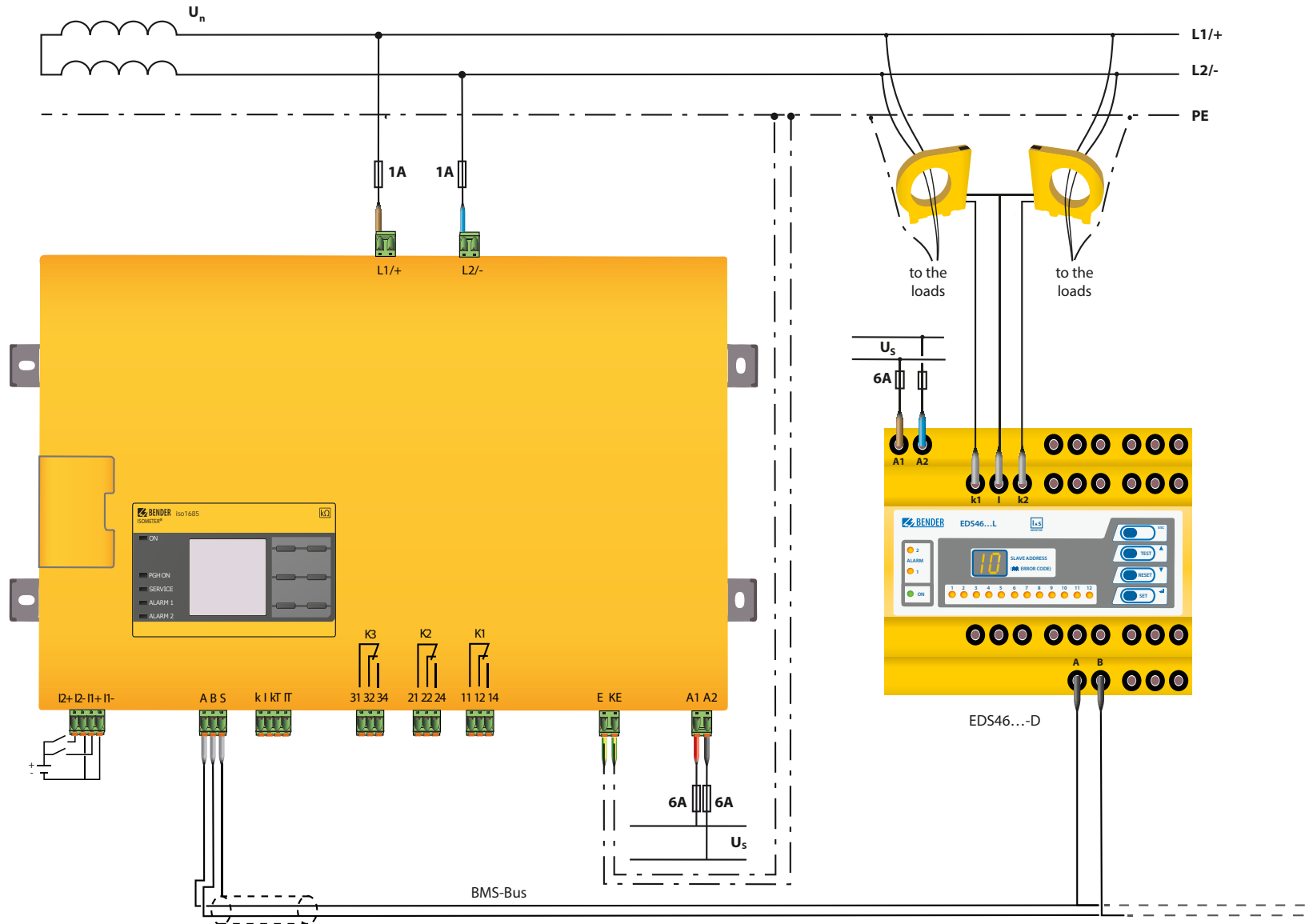

6.1 Commissioning flow chart insulation fault monitoring

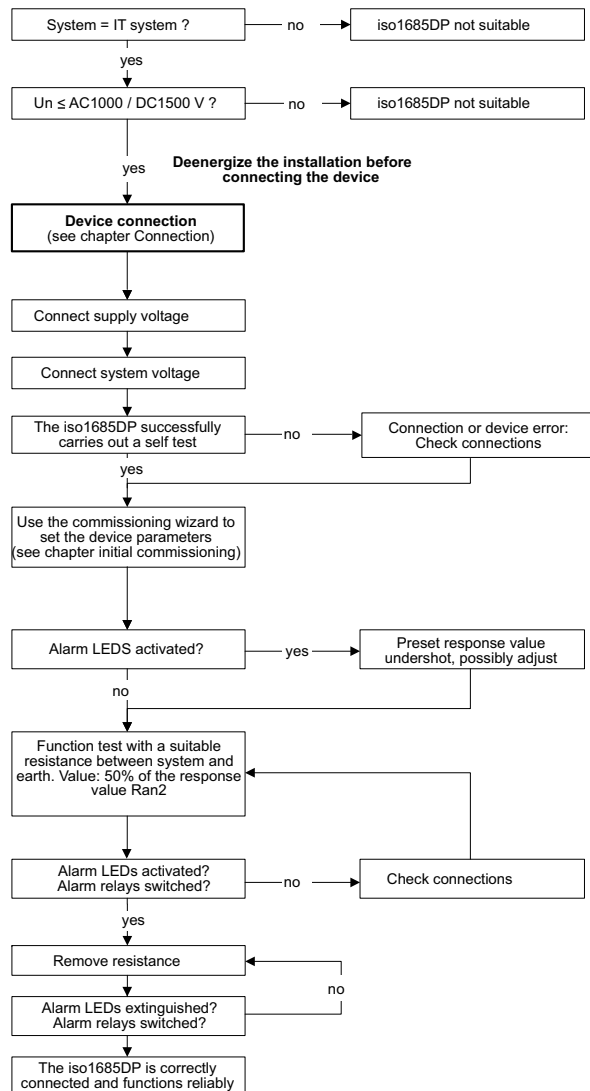

6.2 Commissioning flow chart insulation fault location

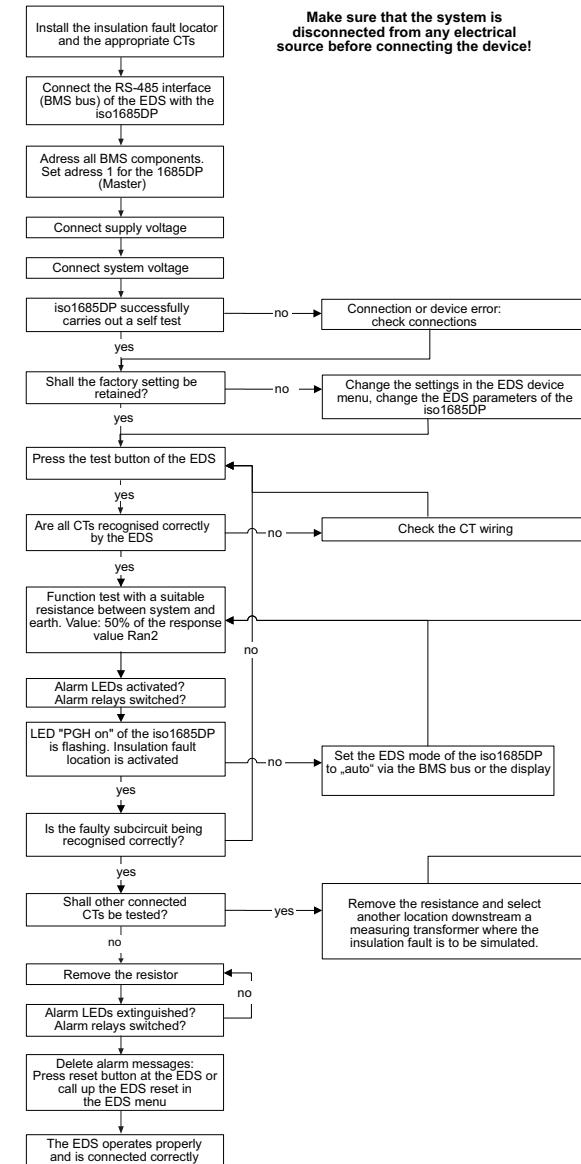

6.3 Initial commissioning

Follow the instructions of the commissioning wizard on the display. Use the device buttons to navigate. For a description of the device buttons, refer to ["Device buttons" auf Seite 16](#).

6.3.1 Setting the language

The language selected here will be used in the menu and for device messages.



6.3.2 Setting date and time

Alarm messages in the history memory and the insulation resistance value over time can only be assigned correctly to the isoGraph when date and time are set correctly.

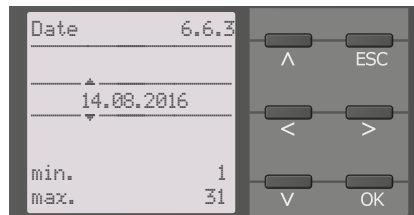
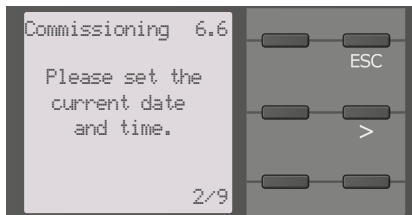

6.3.3 Setting the profile

In order to optimally adapt the insulation monitoring device to the system to be monitored, select a profile here that suits your system. For an overview of the profiles, refer to ["Device profiles" auf Seite 43](#). The profile Power circuits is suitable for most IT systems.

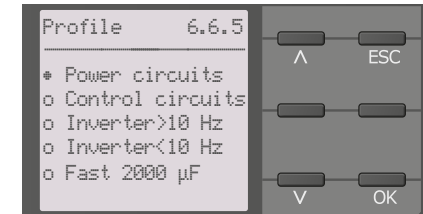
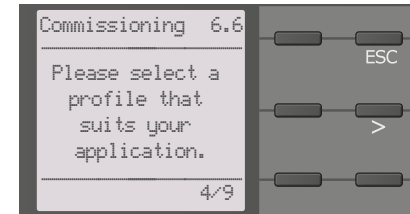

The response value range changes depending on the selected profile. Refer to ["Response values for insulation monitoring" auf Seite 51](#).

6.3.4 Setting response value R_{an1} for Alarm 1

You can set the prewarning response value here.

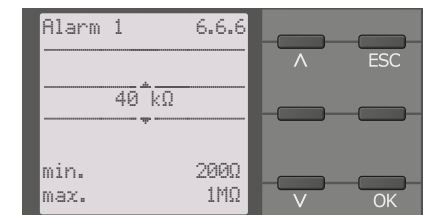
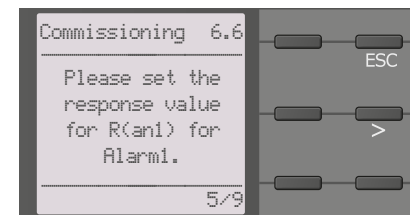

6.3.5 Setting response value R_{an2} for Alarm 2

The response value for the main alarm can be set here.
A value of 50 Ω/V is recommended for the main alarm.

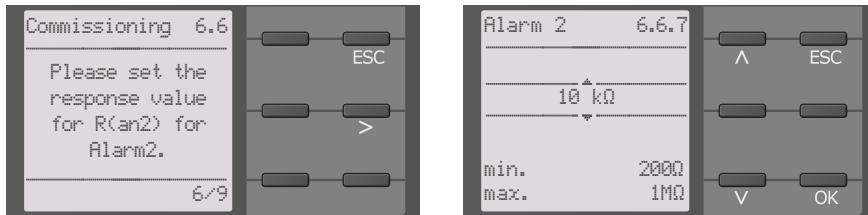

6.3.6 Setting EDS mode

Set the mode for the insulation fault location to manual, automatic or 1 cycle. For further information, refer to "Mode" auf Seite 33.

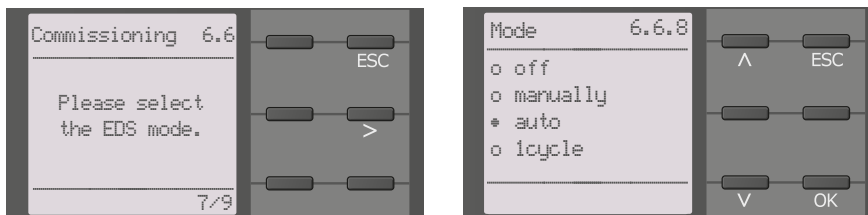

6.3.7 Set the EDS current

Set the maximum locating current.

EDS441: 1-5mA

EDS440: 10-50mA

For further information see "Current" auf Seite 34.

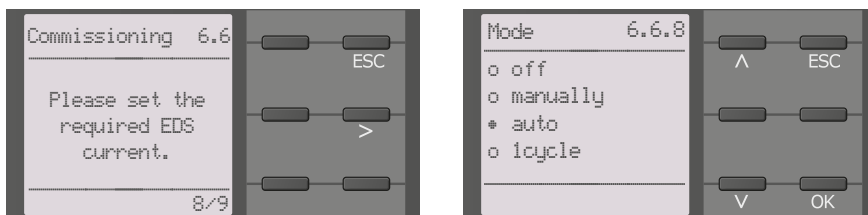

6.3.8 TEST

Set the mode for the insulation fault location to manual, automatic or 1 cycle. For further information, refer to "Mode" auf Seite 33.

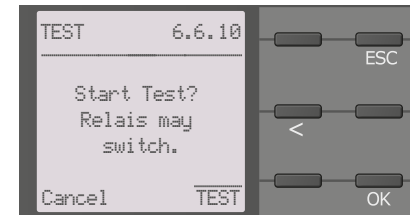

6.4 Recommissioning

If the device has already been put into operation before, the self test will be started shortly after the supply voltage has been connected. You can restart the commissioning wizard using the following menu path:

Menu/Device settings/Commissioning

This menu can be used to modify previously made settings.



Observe device status!

Once initial commissioning has been completed and the initial measurement taken, the device changes from the alarm state to normal state by adhering to the set response values.

If the device has been commissioned before, the self test is not run again. It can be called up via the "Control" menu (refer to Seite 34).

6.5 Commissioning EDS

Proceed as follows to put into operation an EDS after commissioning the ISOMETER®:

1. Set the mode for the insulation fault location to manual, automatic or 1 cycle. For a description of the different modes, refer to ["Mode" auf Seite 33](#).

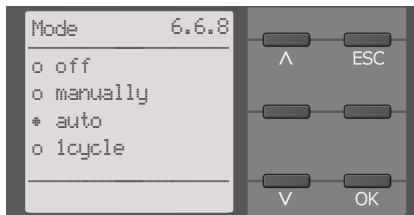

2. Test if the maximum locating current to the EDS is correct and adjust if necessary (refer to [6.3.7 "Set the EDS current" auf Seite 24](#)).

Menu path: Menu/EDS/Current



In addition to this chapter, commissioning of the ISOMETER® in combination with an EDS is described in the ["Commissioning flow chart insulation fault location" auf Seite 22](#).

7. Display

7.1 Standard display

During normal operation, the ISOMETER® displays the message OK and below, the currently measured insulation resistance.

	The signal quality of the measurement suits the selected profile. The better the signal quality, the faster and more exact the device can measure.
	The signal quality of the measurement does not suit the selected profile. Select a different measurement method.
	Update period between the test pulses

In the bottom line of the display, the set limit values for R_{an} are indicated. In the example below, $R_{an1}=40\text{ k}\Omega$ and $R_{an2}=10\text{ k}\Omega$.

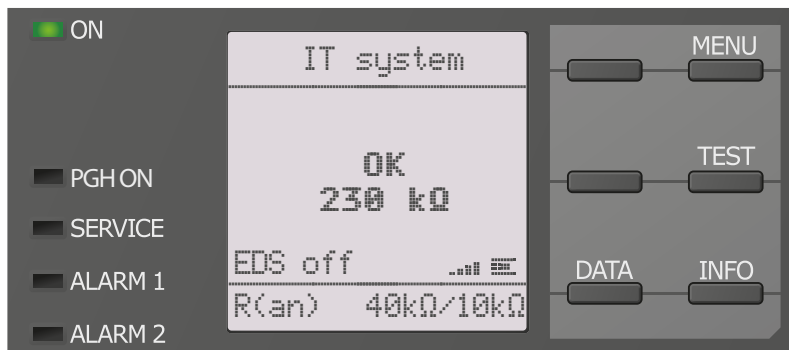

7.2 Fault indication (active)

An active fault is displayed by . The upper part of the display becomes orange and displays the fault message.

Depending on the type of fault, the LEDs ALARM 1, ALARM 2 or SERVICE are activated.

In the example below, the insulation resistance is still $7\text{ k}\Omega$. Since the values $R_{an1}=40\text{ k}\Omega$ and $R_{an2}=10\text{ k}\Omega$ are both below the set response value, ALARM 1 and ALARM 2 have been triggered.

If several fault messages have appeared, you can navigate through the faults using the ∇ and \wedge buttons.

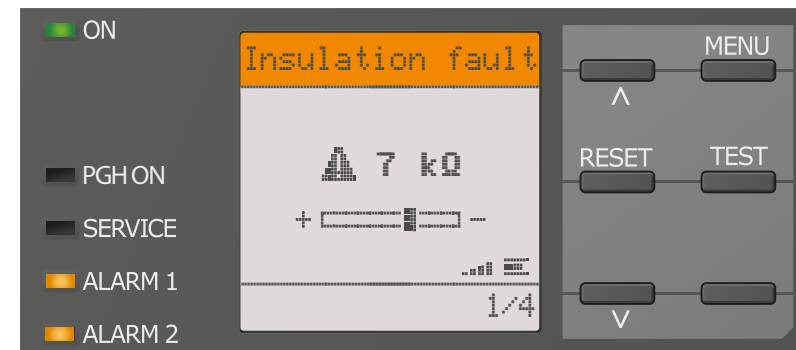



If the value falls below R_{an1} in a DC system or a DC offset is detected in an AC system, additional detailed information regarding the DC offset will be displayed as illustrated above.

7.3 Fault indication (inactive)

An inactive fault is displayed by . If several faults have occurred, the number of faults will also be indicated.

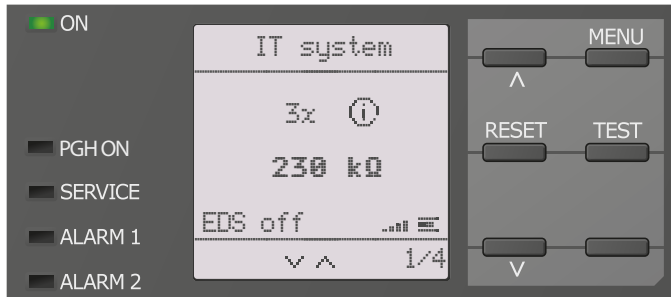
The message shown on the display below means that there has been a fault in the past but the device is no longer in fault condition.



If several fault messages have appeared, you can navigate through the faults using the  and  button. In addition to the type of fault and the associated alarm value, you can see when the fault has occurred and for how long it has been active.

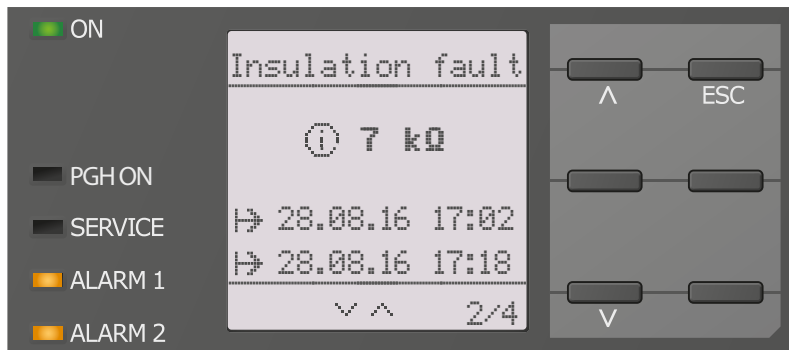

7.4 Acknowledging a fault message

In order to acknowledge the fault message and return to the ISOMETER®'s standard display, all faults must be acknowledged by means of the reset button.

This means that fault messages can only be reset when the cause of fault has been eliminated.

Press the reset button, then  and OK to clear the fault memory. The ISOMETER® then returns to the standard display.

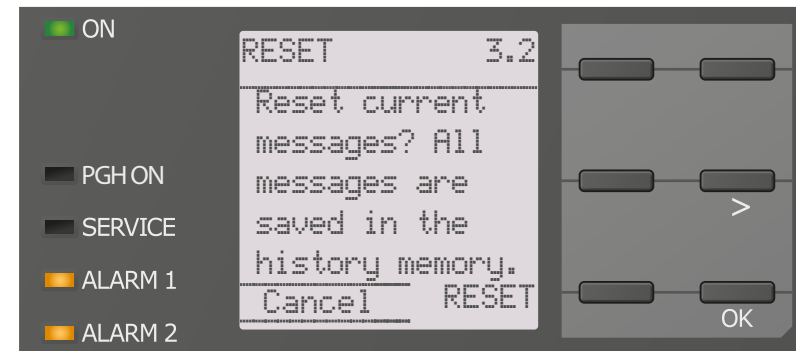

7.5 Data - isoGraph

The isoGraph represents the chronological sequence of the insulation resistance over time.

This graphical representation can be displayed over the following time periods: hour, day, week, month and year.

The measured values for individual representations are stored in a separate memory. Measured values for insulation, voltage, PGH current (current of the locating current injector) and the temperature of the coupling and the locating current injector are indicated. You can switch the indication of the different measured values by pressing ∇ . Up to 100 measured values are available to represent each graph and the resolution of each graph is determined by these values.

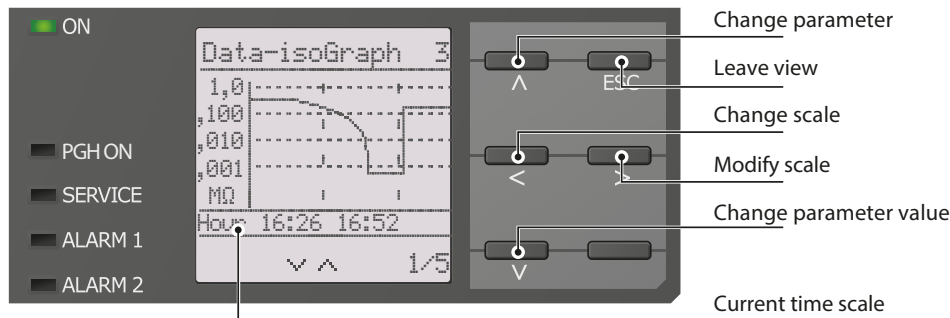

7.6 History memory

Up to 1023 alarm messages and device errors are stored in the history memory with date and time stamp. If the history memory is deleted, the minimum insulation resistance R_{min} will also be reset at Menu/Data Measured values - Data insulation.

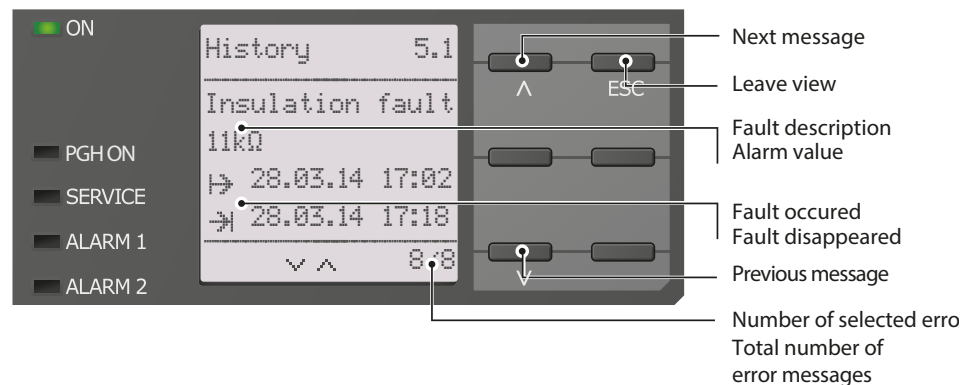

7.7 Insulation fault location

When the EDS mode is activated, the ISOMETER® indicates the message "Ins. fault locat.". Below, it indicates which EDS mode is activated. On the right side it indicates the polarity change of the measuring pulses including the pause in between.

	Measuring pulse rising edge
	Pause
	Measuring pulse falling edge
EDS off	The insulation fault location function has been deactivated
EDS auto	The insulation fault location is in "auto" mode (see diagram below)
EDS 1 cycle	The insulation fault location is in "1 cycle" mode
EDS manual	The insulation fault location is in "manual" mode

An active fault is indicated by . The upper part of the display becomes orange and displays the fault message. The alarm LEDs are lit. If several fault messages have appeared, you can navigate through the faults using the ∇ and \wedge buttons.

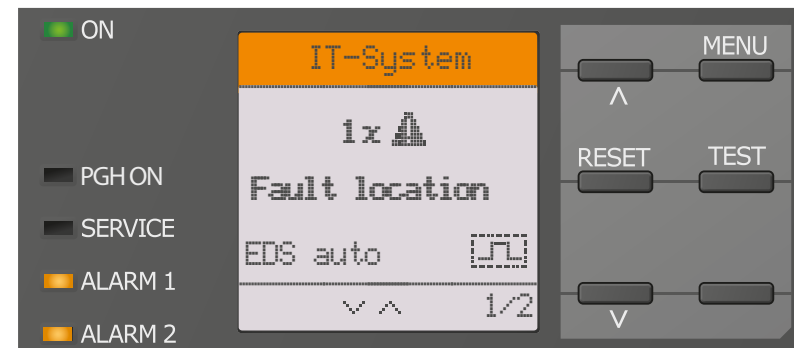

For further information regarding the different modes, refer to "Mode" auf Seite 33

8.1 Overview of the device menu

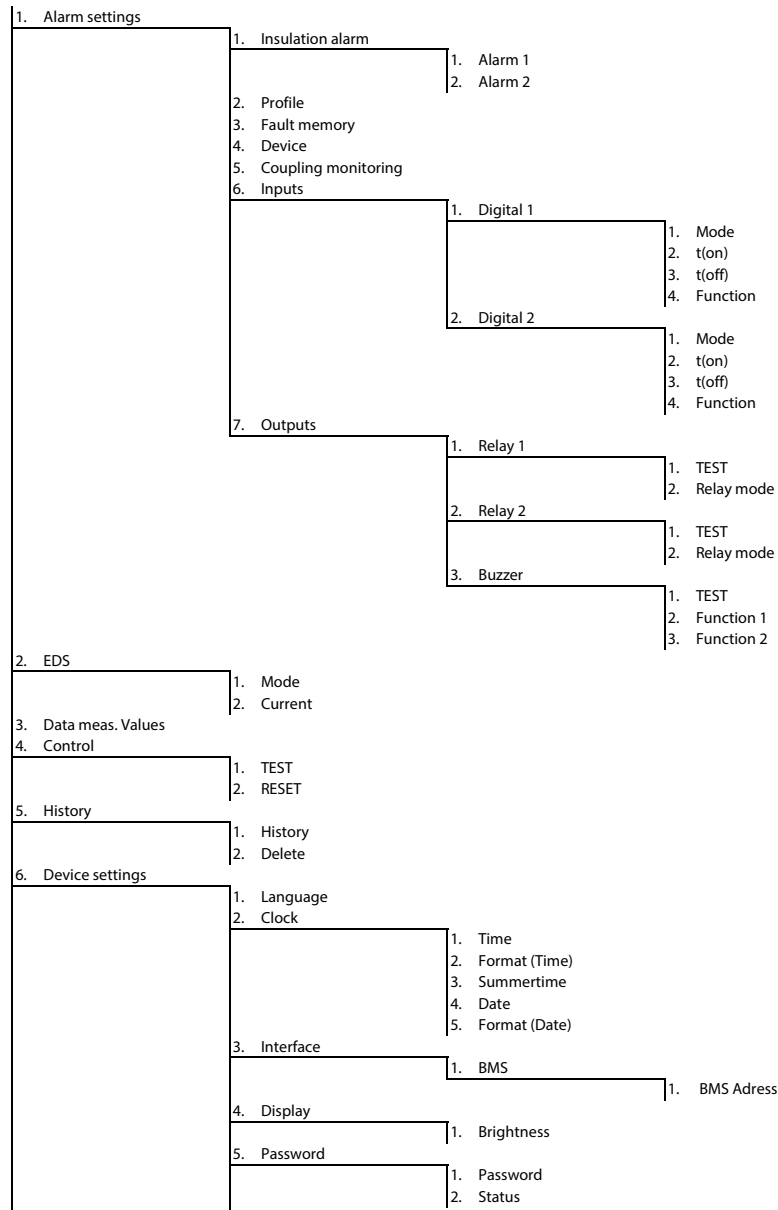

8.2 Operation and Navigation

Navigate through the device menu using the device buttons. The functions of the device buttons are described in the chapter "Device buttons" auf Seite 16.

Navigation in lists

To make a selection in a list, navigate using the ∇ and \blacktriangle buttons to the required menu item. Then click "OK".

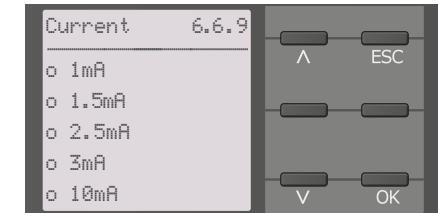

Navigation with arrows

You can increase or decrease a value using the ∇ and \blacktriangle buttons. You can move to the left or the right to set different values using the \leftarrow and \rightarrow buttons. The value positioned between the \blacktriangle symbols is the value that is set.

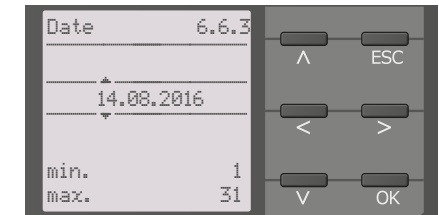

The settings of the ISOMETER® are explained in the order of the device menu.

9.1 1.0 Alarm settings

The limit values for the insulation resistances of alarm 1 and alarm 2 can be specified in the alarm settings menu and adjusted to the profile of the ISOMETER®. If you have activated the password query in the device menu (refer to “Password” auf Seite 36), you must enter the device password in order to change the settings.

You can adjust the following functions:

9.1 (1.1) Insulation alarm

In the Insulation alarm menu, the ISOMETER® limit values for alarm 1 and alarm 2 can be set. Activation or deactivation of the two alarm levels R_{an1} (alarm 1) and R_{an2} (alarm 2) are illustrated in the following graphic:

An alarm will become inactive as soon as the hysteresis of the set operating value is exceeded.

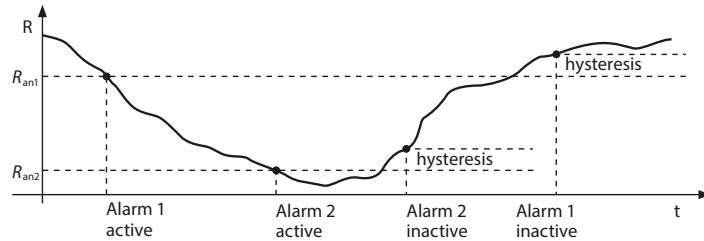

9.1 (1.1.1) Alarm 1

An insulation resistance of 0.2 kΩ...1 MΩ can be set for alarm 1.
Condition: alarm 1 ≥ alarm 2.

9.1 (1.1.2) Alarm 2

An insulation resistance of 0.2 kΩ...2 MΩ can be set for alarm 2.

9.1 (1.2) Profile

Adapt the area of application of the ISOMETER® to your system profile. For a description of the profiles, refer to “Device profiles” auf Seite 43.

The following can be selected:

- *Power circuits Suitable for most IT systems.
- *High capacitance Suitable for system with high leakage capacitances.
Limit of the measuring range: 200 kΩ
- *Inverter > 10 Hz Suitable for systems with dynamic frequency control by inverters in the range 10 to 460 Hz.
- *Inverter < 10 Hz Suitable for systems with extremely low frequency control in the range 1...460 Hz.
- *Fast 2000 μF Suitable for systems with very high leakage capacitances, e.g. in large-scale photovoltaic systems.
Limit of the measuring range: 50 kΩ

9.1 (1.3) Fault memory

Automatic reset of inactive faults at the outputs (relays 11-12-13, 21-22-24, 31-32-34):

- *on If a fault becomes inactive, the programmed outputs remain in fault condition until they are reset manually.
- *off If a fault becomes inactive, the programmed outputs automatically change the state.

9.1 (1.4) Device

Set the ISOMETER® insulation resistance measurement function to active or inactive:

- *Active The device is active.
- *Inactive The device DOES NOT measure the insulation resistance and is disconnected from the system to be monitored (system disconnection). The IT system is NOT being monitored! The message *Device inactive* appears on the display. The ALARM1 and ALARM2 LEDs are lit.

9.1 (1.5) Coupling monitoring

The ISOMETER® continuously monitors the coupling of energised systems. The coupling of de-energised systems is monitored at 24-hour intervals. This monitoring function can be activated or deactivated.

- *on Coupling monitoring is activated.
- *off Coupling monitoring is deactivated.

9.1 (1.6) Inputs

The ISOMETER® provides 2 digital inputs (I1, I2) that are freely configurable.

9.1 (1.6.1) Digital 1

The following parameters can be set for the digital input:

9.1 (1.6.1.1) Mode

The operating mode for the digital input can be set to the following values:

- *Active high An event is carried out on the rising edge of the digital input (low to high). Response time $t(on)/t(off)$ after a switch-on signal.

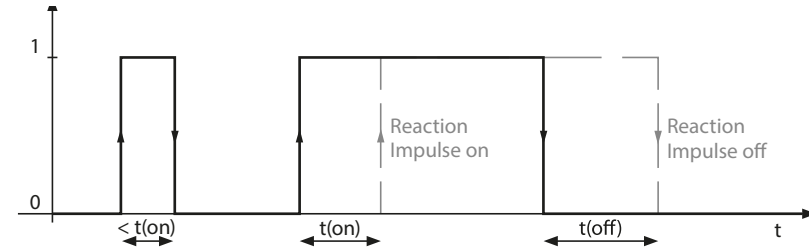
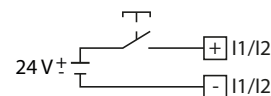

*Active low

An event is carried out on the falling edge of the digital input (high to low). Response time $t(on)/t(off)$ after a switch-off signal.

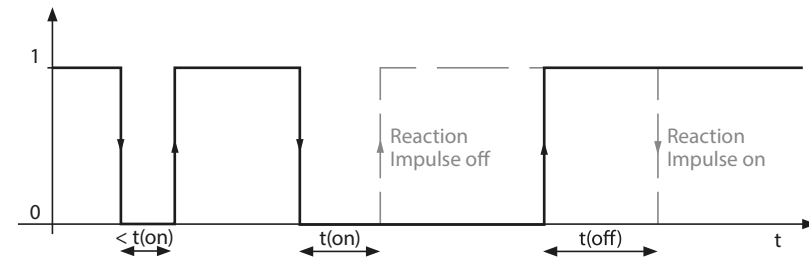
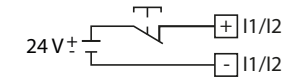

9.1 (1.6.1.2) $t(on)$

The response time $t(on)$ after a switch-on signal can be set between 100 milliseconds and 300 seconds.

9.1 (1.6.1.3) $t(off)$

The response time $t(off)$ after a switch-off signal can be set between 100 milliseconds and 300 seconds.

9.1 (1.6.1.4) Function

The parameters for the function of the digital inputs of the ISOMETER® can be set differently:

*off	Digital input without function
*TEST	Device self test
*RESET	Reset of fault and alarm messages
*Deactivate device	The device DOES NOT measure the insulation resistance, the message <code>Device inactive</code> appears on the display. The IT system is NOT being monitored! The device uncouples itself from the system to be monitored through an internal system isolating switch.
*Insulation fault location	The insulation fault location is started. For this purpose, the digital input must be active.

9.1 (1.6.2) Digital 2

Refer to ["9.1 \(1.6.1\) Digital 1"](#).

9.1 (1.7) Outputs

The ISOMETER® provides a total of 3 alarm relays.

The following parameters can be set for relay 1 and relay 2:

9.1 (1.7.1) Relay 1

The following parameters can be set for the relay:

9.1 (1.7.1.1) TEST

The functional test of the relay can be activated or deactivated. This only applies to the manual test and not to the cyclic device self test:

*on	The manual test checks the switching function of the relay
*off	The manual test does not check the switching function of the relay

9.1 (1.7.1.2) Operating mode

The relay mode can be adapted to the application:

*N/C	Normally closed - N/C operation contacts 11-12-14/21-22-24 (The alarm relay is energised during normal operation).
*N/O	Normally open - N/O operation contacts 11-12-14/21-22-24 (The alarm relay is de-energised during normal operation).

9.1 (1.7.2) Relay 2

Refer to ["9.1 \(1.7.1\) Relay 1"](#).

Relay 3:

Relay 3 does not appear in the device menu. The operating mode is set to N/C operation and the parameters cannot be adjusted.

9.1 (1.7.3) Buzzer

The following parameters can be set for the buzzer:

9.1 (1.7.3.1) TEST

The functional test of the buzzer can be activated or deactivated. This only applies to the manual test and not to the cyclic device self test:

*on	The manual test activates the buzzer sound.
*off	The manual test does not activate the buzzer sound.

9.1 (1.7.3.2) Function 1

The following parameters can be set:

*off	The function is not used.
*Ins. alarm 1	The status of the output changes when the value falls below the set response value R_{an1} .
*Ins. alarm 2	The status of the output changes when the value falls below the set response value R_{an2} .
*Connection fault	The status of the output changes when one of the following connection faults occurs: <ul style="list-style-type: none"> • No low-resistance connection between the line conductors. • No low-resistance connection between the terminals E and KE to earth (PE).
*Device error	The status of the output changes in the event of an internal device error.
*Common alarm	The status of the output changes on the occurrence of any alarm and fault messages (Ins. alarm 1 & 2, DC-/DC+ alarm, symmetrical alarm, connection and device errors).
*Device inactive	The status of the output changes when the device has been deactivated via a digital input or the control menu.

9.1 (1.7.3.3) Function 2

Refer to "9.1 (1.7.3.2) Function 1".

9.1 2.0 EDS (insulation fault location)



Setting the parameters for insulation fault locators EDS44...-L via the ISOMETER® iso1685DP is NOT possible yet. If you cannot make the settings directly on the insulation fault locator, you can use another device, e.g. COM460IP or MK2430, to set the parameters.

9.1 (2.1) Mode

To locate insulation faults, select one of the four available modes for insulation fault location.

*off	The insulation fault location is deactivated.
*Manual	In manual mode, the insulation fault location starts immediately. If you start the insulation fault location, it remains active without considering the insulation resistance and the alarm message of the ISOMETER®.
*auto	In auto mode, the insulation fault location starts automatically as soon as the response value of alarm 2 of the ISOMETER® has fallen below the preset value. The insulation fault location is cyclically interrupted for an insulation measurement. If the insulation fault still exists after the interruption, the insulation fault location starts again. The insulation fault location only stops if alarm 2 is inactive. If a new insulation fault appears, the insulation fault location restarts automatically.
*1 cycle	In 1-cycle mode, the insulation fault location starts automatically as soon as the response value of alarm 2 of the ISOMETER® has fallen below the preset value. The insulation fault location is stopped after one cycle. If the insulation fault still exists after the interruption, the insulation fault location does NOT start again. If a new insulation fault appears, the insulation fault location restarts automatically for one cycle.

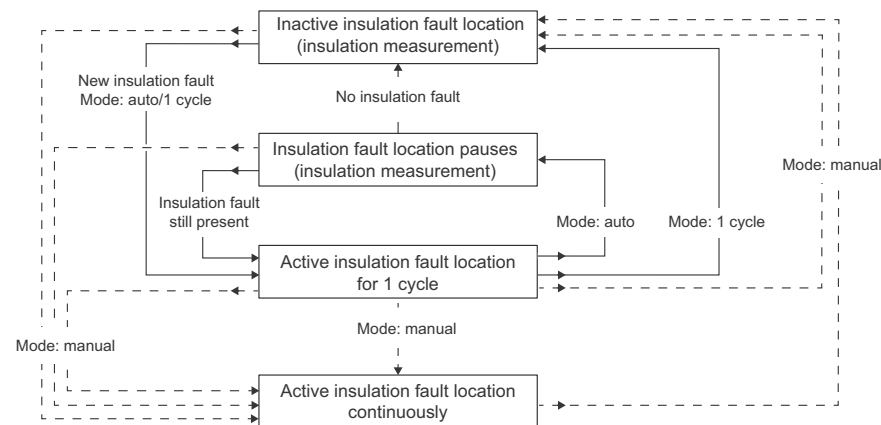

9.1 (2.2) Current



Risk of malfunctions due to excessive locating current on sensitive system parts!

The locating current flowing between the IT system and earth can cause controller faults in sensitive parts of the system, such as the PLC or relay. Ensure that the level of the locating current is compatible with the system to be monitored.

Set the maximum locating current on the ISOMETER®. You can find the device-specific maximum locating currents in the table below.

*1 mA	for EDS441..., EDS461..., EDS491...
*1.5 mA	for EDS441..., EDS461..., EDS491...
*2.5 mA	for EDS441..., EDS461..., EDS491...
*3 mA	for EDS441..., EDS461..., EDS491...
*10 mA	for EDS440..., EDS460..., EDS490...
*12.5 mA	for EDS440..., EDS460..., EDS490...
*25 mA	for EDS440..., EDS460..., EDS490...
*50 mA	for EDS440..., EDS460..., EDS490...

9.1 3.0 Data measured values

The ISOMETER® stores certain measured values for a specific period of time. You can view these data at the "Data meas. values" menu item. Navigate through the different views using the \wedge and \vee buttons:

*Data - isoGraph	Displays the insulation resistance and chronological sequence.
*Data - Insulation	Displays the current insulation resistance and the system leakage capacitance.
*Data - Voltage	Displays the system voltages.
*Data - PGH	Displays measuring current, locating current, performance and insulation fault location mode.
*Data - Temperature	Coupling system and locating current injector

9.1 4.0 Control

In the Control menu, you can run a manual test and reset the alarm messages:

*TEST	Manual device test
*RESET	Reset of fault and alarm messages

9.1 5.0 History

In the history menu, the faults detected by the ISOMETER® are displayed. For a detailed description, refer to "[History memory](#)" auf Seite 28.

*History	Overview of faults that have occurred
*Delete	Reset the history memory

9.1 6.0 Device settings

The device settings menu allows configuring the basic settings for the ISOMETER®:

9.1 (6.1) Language

Choose the language to be displayed by the ISOMETER®. For example, you can set the languages:

- *German
- *English
- *...

9.1 (6.2) Clock

In the clock menu, you can set the display format of date and time for the ISOMETER®:

9.1 (6.2.1) Time

Based on the selected time format you can set the current time to display 24-hour or 12-hour notation (am/pm).

9.1 (6.2.2) Format (time)

Select the appropriate time format to be displayed:

- *12 h 12-hour notation am/pm
- *24 h 24-hour notation

9.1 (6.2.3) Summer time

Summer time can be considered in the following settings:

- *off No automatic change between summer time and standard time.
- *DST Daylight Saving Time
Automatic change between summer and standard time according to North American regulation.
North American summer time begins on each second Sunday in March at 02:00 local time by setting the clock forward by one hour from 2:00 to 03:00 local time. Summer time always ends the first Sunday in October at 03:00 local time by setting the clock back one hour from 3:00 to 2:00.
- *CEST Central European Summer Time
Automatic change between summer time and standard time according to Central European regulation.
Central European summer time begins on each last Sunday in March at 02:00 CEST by setting the clock forward by one hour from 2:00 to 03:00. Central European summer time always ends on the last Sunday in October at 03:00 CEST by setting the clock back one hour from 3:00 to 2:00.

9.1 (6.2.4) Date

Based on the selected date format you can set the current date.

9.1 (6.2.5) Format (date)

Select the appropriate date format to be displayed:

- *dd.mm.yy day, month, year
- *mm-dd-yy month, day, year

9.1 (6.3) Interface

Set the parameters for connection of other devices to the ISOMETER® in the interface menu:

9.1 (6.3.1) BMS

Set the parameters for communication with other devices via the BMS bus.

9.1 (6.3.1.1) BMS address

Select an address between 1 and 90 for the BMS bus.

9.1 (6.4) Display

Adjust the display brightness for the ISOMETER® in the display menu:

9.1 (6.4.1) Brightness

Adjust the display brightness between 0 % and 100 % in steps of 10.

If no button is pressed on the display for 15 minutes, the brightness of the display will be reduced. If now a button is pressed, the normal brightness is restored.

9.1 (6.5) Password

Use the password function to protect the device parameters against unauthorised adjustment. The default password is 0000.

9.1 (6.5.1) Password

Enter an individual four-digit password.

9.1 (6.5.2) Status

Decide whether the password query should be used:

*on	Password query active
*off	Password query inactive

9.1 (6.6) Commissioning

In the commissioning menu, you can open the ISOMETER®'s commissioning wizard again.

9.1 (6.7) Service

The service menu can only be accessed by Bender service staff.

9.1 7.0 Info

The ISOMETER®'s current settings can be viewed in the Info menu. Navigate through the different views using the \wedge and \vee buttons:

*Info - Device	Device name, serial number, article number
*Info - Software	Software version measurement technique, software version HMI
*Info - Measurement technique	Set profile, locating current and EDS mode
*Info - Clock	Time, date, summer time
*Info - BMS	Address of the RS-485 interface

9.2 Factory settings

Response values, alarms and profile

Parameter	Value Status
Measurement method	Power circuits
Insulation response value R_{an1}	40k Ω
Insulation response value R_{an2}	10k Ω
Fault memory	off
Coupling monitoring	on

Switching elements

Parameter	Value Status
Relay 1 (11/12/14)	Operating mode: N/C operation Function: Insulation measurement
Relay 2 (21/22/24)	Operating mode: N/C operation Function: Insulation measurement
Relay 3 (31/32/34)	Operating mode: N/C operation Function: Device error

Insulation fault location

Parameter	Value Status
EDS mode	auto
PGH current	25 mA

BMS

Parameter	Value Status
BMS address	2
BMS termination	ON

Digital inputs

Parameter	Value Status
Digital input 1	Mode (operating mode): active high Function: Test
Digital input 2	Mode (operating mode): active high Function: standby

Other

Parameter	Value Status
Standby mode (disconnection from the mains)	off
Permissible system leakage capacitance	depending on the set measurement method (refer to "12. Device profiles")
Buzzer	off
Menu language	German
Password query	off
Password	0000

10.1 RS-485 interface with BMS protocol

The RS-485 interface, galvanically isolated from the device electronics, serves as a physical transmission medium for the BMS protocol. When an ISOMETER® or other bus-capable devices are interconnected via the BMS bus in a network, the BMS bus must be terminated at both ends with a 120 Ω resistor. For this purpose, the device is equipped with the terminating switch RS-485 Term. (ON/OFF).

An RS-485 network that is not terminated is likely to become unstable and may result in malfunctions. Only the first and last device in one line may be terminated. Hence, stub feeders in the network must not be terminated. The length of the stub feeders is restricted to 1 meter.

10.2 Topology RS-485 network

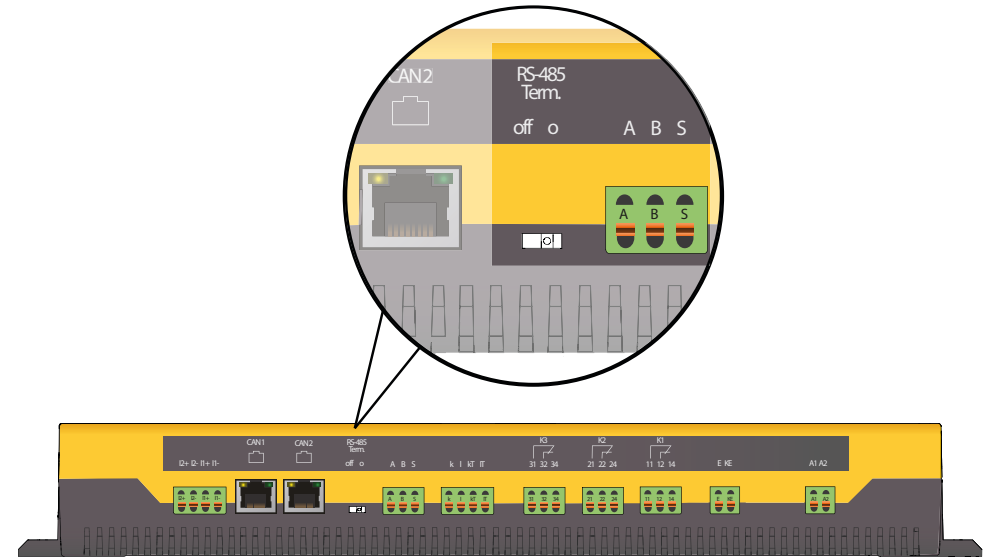
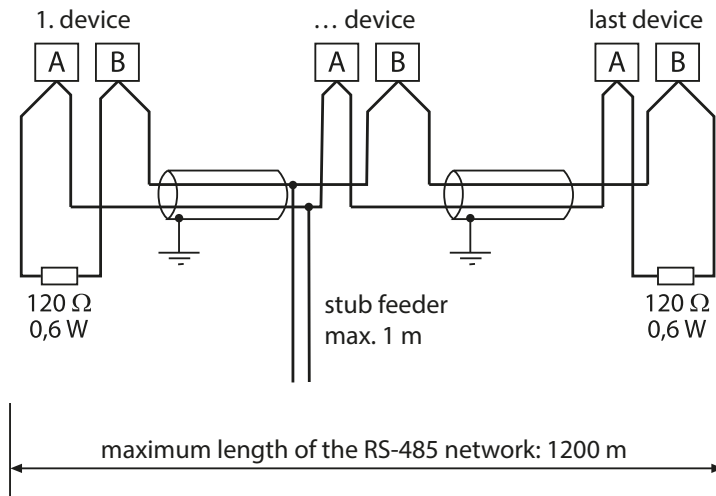

The optimum topology for an RS-485 network is a daisy-chain connection. In this connection, device 1 is connected to device 2, device 2 to device 3, device 3 to device n etc. The RS-485 network represents a continuous path without branches.

Correct arrangement

Three examples for correct arrangement:

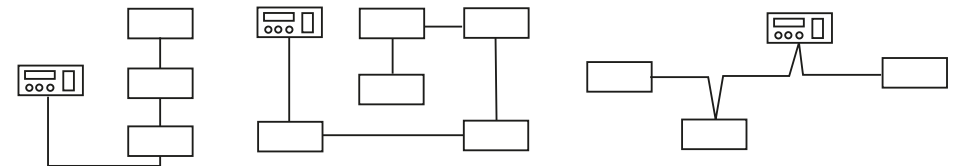

Wrong arrangement

Three examples for wrong arrangement:

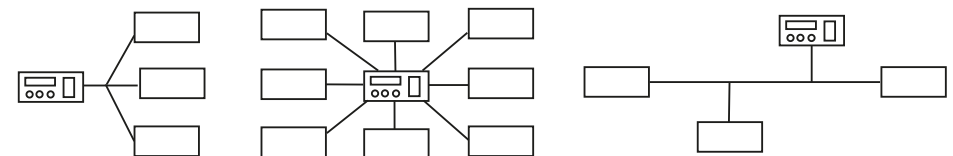

Wiring

The following type of wiring is recommended for the RS-485 network:

Shielded cable, core diameter ≥ 0.8 mm

(e.g. J-Y(St)Y 2x0.8), shield connected to earth (PE) on one end.

Connection to terminals A and B.

The number of bus nodes is restricted to 32 devices. If more devices are to be connected, Bender recommends the use of a DI1 repeater.

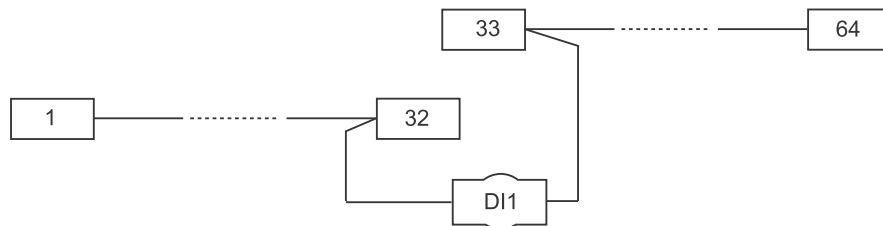

10.3 BMS protocol

This protocol is an essential part of the Bender measuring device interface (BMS bus protocol). Data transmission generally makes use of ASCII characters.

Interface data are:

- Baud rate: 9600 baud
- Transmission: 1 start bit, 7 data bits, 1 parity bit, 1 stop bit (1, 7, E, 1)
- Parity: even
- Checksum: sum of all transmitted bytes = 0 (without CR and LF)

The BMS bus protocol works according to the master-slave principle. Only one master may exist in each network. All bus devices are identified by a unique BMS address. The master cyclically scans all other slaves on the bus, listens to their signals and then carries out the corresponding commands.

A device receives the MASTER function by assigning **Bus address 1** to it.

10.4 BMS master

A master can query all measured values, alarm and operating messages from a slave. If bus address 1 is assigned to a device, this device automatically represents the master, i.e. all addresses between 1 and 150 are cyclically scanned via the BMS bus for alarm and operating messages. If the master detects incorrect answers from a slave, the fault message "Fault RS-485" will be output via the BMS bus.

Fault causes may be:

- Addresses are assigned twice
- A second master exists on the BMS bus
- Interference signals occur on the bus lines
- A defective device is connected to the bus
- Terminating resistors are not activated or connected

10.5 Commissioning of an RS-485 network with BMS protocol

- Interconnect terminals A and B of all bus devices in one line
- Switch the terminating resistors on at the start and the end of the RS-485 network. If a device at the end of the bus is not terminated, connect a 120 Ω resistor to terminals A and B
- Switch the supply voltage on
- Assign the master function and address 1 to a bus-capable device
- Assign addresses (2...90) to all other bus devices in consecutive order

10.6 Setting BMS address



The ISOMETER® cannot switch on a potential termination at the BMS bus. Even though this is not expected to cause communication problems, the ISOMETER® should be operated as BMS slave if possible (BMS address > 1). If no other device with master capabilities is available on the bus, the ISOMETER® can be set to master (BMS address 1).



Before the ISOMETER® takes over the backup master function after being switched on, it waits to see if another master connects itself to the system. Waiting period: BMS address minus 1 = waiting period in minutes. Example: The iso1685DP has BMS address 3. It waits 3 minus 1 minutes (= 2 minutes) for a master to connect.

Set the BMS address ((1)2...90) in the device menu via the path:

Device settings/Interface/BMS/BMS Address.

10.7 Alarm and operating messages via the BMS bus

Messages are transmitted to a maximum of 12 BMS channels. All alarm and operating messages that may occur are described below.

10.7.1 Alarm messages

Message	Channel	Description
Alarm 1 (insulation fault)	1	Insulation resistance "prewarning" (Value < response value 1, $R_F < R_{an1}$)
Alarm 2 (insulation fault)	2	Insulation resistance "alarm" (Value < response value 2, $R_F < R_{an2}$)
Connection system	4	Connection fault system
Connection PE	5	Connection fault earth
Device error	7	Internal device error
Start insulation fault location		The insulation fault location is started
Overtemperature coupling	10	Overtemperature coupling terminal L1/+
Overtemperature coupling	11	Overtemperature coupling terminal L2/-
Overtemperature PGH	12	Overtemperature of the locating current injector

10.7.2 Operating messages

Message	Channel	Description
Insulation resistance	1	Current insulation resistance R_F (when $R_F > (R_{an1} + \text{hysteresis})$)
Insulation resistance	2	Current insulation resistance R_F (when $R_F > (R_{an2} + \text{hysteresis})$)
Leakage capacitance	4	Leakage capacitance C_e in nF, μF
Mains voltage	5	Current system voltage U_N
Partial voltage U+/PE	6	Current partial voltage terminal L1/+ to earth
Partial voltage U-/PE	7	Current partial voltage terminal L2/- to earth
PGH current	8	Current PGH locating current (when the EDS system is active)
Temperature coupling	10	Current temperature of the coupling L1/+
Temperature coupling	11	Current temperature of the coupling L2/-
Temperature PGH	12	Current temperature of the locating current injector

10.7.3 Resetting error messages

Recorded errors are provided as alarm messages on the BMS bus.

The fault messages are reset via the device menu. If the error continues to exist, the message will be generated again. The error can also be reset by means of the acknowledgement command via the BMS bus.

10.7.4 Error codes

The following list contains all relevant error codes output via the BMS bus. The right-hand column describes the relevant action to be taken in each case.

BMS error code	Components	Fault	Action
0.30	Connection	Connection earth (E/KE)	Check connection
0.40	Connection	Connection system (L1/+, L2/-)	Check connection
4.05	Parameter	Incorrect measurement method selected	Change measurement method
7.63	System	Timeout system management	Restart the device
8.11	Hardware	Self test insulation measurement	Contact service
8.12	Hardware	Hardware measuring voltage source	Replace device
8.31	Hardware	PGH: locating current too high	Replace device
8.32	Hardware	PGH: locating current cannot be switched off	Replace device
8.42	Hardware	Supply voltage ADC	Replace device
8.43	Hardware	Supply voltage +12 V	Replace device
8.44	Hardware	Supply voltage -12 V	Replace device
8.45	Hardware	Supply voltage +5 V	Replace device
8.46	Hardware	Supply voltage +3.3 V	Replace device
9.61	Parameters	Insulation measurement	Load factory settings and set parameters again
9.63	Parameters	Locating current injector	Load factory settings and set parameters again
9.64	Parameters	Voltage measurement	Contact service
9.70	System	General software error	Restart the device
9.71	System	Control flow	Restart the device
9.72	System	Programme sequence insulation measurement	Restart the device

BMS error code	Components	Fault	Action
9.74	System	Programme sequence locating current injector	Restart the device
9.75	System	Programme sequence voltage measurement	Restart the device
9.76	System	Programme sequence temperature measurement	Restart the device
9.77	System	Programme sequence history memory	Restart the device
9.78	System	Programme sequence console	Restart the device
9.79	System	Programme sequence self test	Restart the device
9.80	System	Stack error	Restart the device
9.81	System	Internal programme sequence	Restart the device
9.82	System	Internal programme sequence	Restart the device

11.1 General description

An additional function of the ISOMETER® in combination with the EDS is the selective insulation fault location. The insulation faults detected in the IT system by the ISOMETER® can be located by means of an EDS and measuring current transformers. For further information regarding the operating principle of the insulation fault location, refer to [3.3.2 "Insulation fault location" auf Seite 11](#).

11.2 Required settings for insulation fault location

Connecting and commissioning the system consisting of ISOMETER® and EDS correctly.

For further information regarding the connection of the EDS, refer to [5.2.3 "Connecting the EDS to the ISOMETER®" ab Seite 18](#), at [6.2 "Commissioning flow chart insulation fault location" auf Seite 22](#) and to the corresponding manual of the EDS.

Setting locating current and EDS mode.

These settings can be made either during initial commissioning (see [6.3 "Initial commissioning" ab Seite 23](#)) or in the device menu of the ISOMETER® (see [9.1 2.0 "EDS \(insulation fault location\)" ab Seite 33](#)).

For further information regarding the locating current for insulation fault location, refer to [9.1 \(2.2\) "Current" auf Seite 34](#).

For further information regarding EDS modes, refer to [9.1 \(2.1\) "Mode" auf Seite 33](#).

11.3 Indication on the display

The active insulation fault location is indicated on the display of the ISOMETER®.

For further information, refer to [7.7 "Insulation fault location" ab Seite 28](#).

11.4 Starting and stopping the insulation fault location

The insulation fault location can be started and stopped via different interfaces:

- Device menu
- Digital input

For further information regarding start and stop conditions of the insulation fault location, refer to [9.1 \(2.1\) "Mode" auf Seite 33](#).

12. Device profiles

	Nominal system voltage	Mains frequency	System leakage capacitance	Measuring voltage	Description
Power circuits	AC 0...1000 V/ DC 0...1500 V	DC, 15...460 Hz	0...150 μ F	\pm 50 V	Main circuits without dynamic frequency changes. The universal profile is suitable for all systems primarily with constant mains frequencies and extraneous DC voltages. When using inverters and dynamic frequency control, select Inverter > 10 Hz or Inverter < 10 Hz.
High capacitance	AC 0...1000 V/ DC 0...1500 V	DC, 15...460 Hz	0...500 μ F	\pm 50 V	For systems with high leakage capacitances, e.g. ship applications, the impact of leakage capacitances on the measuring result can be significantly reduced by selecting this profile.
Inverter > 10 Hz	AC 0...1000 V/ DC 0...1500 V	DC, 10...460 Hz	0...150 μ F	\pm 50 V	This profile is used for systems with dynamic frequency control by inverters in the range 10 to 460 Hz in order to optimise the measurement with respect to the measuring time and quality.
Inverter < 10 Hz	AC 0...1000 V/ DC 0...1500 V	DC, 1...460 Hz	0...150 μ F	\pm 50 V	For systems involving extremely low-frequency control in the range of up to 1...460 Hz and very low and continuously changing extraneous DC voltages due to dynamic load conditions in an IT system, continuous insulation monitoring can be optimised using this profile.
Fast 2000 μF	AC 0...1000 V/ DC 0...1500 V	DC, 15...460 Hz	0...2000 μ F	\pm 50 V	For systems with very high leakage capacitances, e.g. in large-scale photovoltaic systems, this profile ensures correct measurement.



The response value range changes depending on the selected profile. Refer to "Response values for insulation monitoring" auf Seite 51.

13. Alarm messages

Alarm message	Description	Actions	Reference	LED indicators
Alarm 1 (insulation fault)	The insulation resistance is lower than the response value R_{an1}	<ul style="list-style-type: none"> Determine cause of the insulation fault and eliminate it. 	See chapter “Alarm messages” ab Seite 44.	ALARM 1 is lit
Alarm 2 (insulation fault)	The insulation resistance is lower than the response value R_{an2}	<ul style="list-style-type: none"> Determine cause of the insulation fault and eliminate it. 	See chapter “Alarm messages” ab Seite 44.	ALARM 2 is lit
Connection system	Connection fault system (available from software version 2.x)	<ul style="list-style-type: none"> Check the wiring of terminals L1/+, and L2/- to the IT system Press the test button Check mains voltage Check fuses 	See chapter “Connection” ab Seite 17.	ALARM 1 + ALARM 2 flash in common mode
Connection PE	Connection fault. E/KE not connected to PE	<ul style="list-style-type: none"> Check the wiring of terminals E and KE to earth (PE) Press the test button 	See chapter “Connection” ab Seite 17.	ALARM 1 + ALARM 2 flash in common mode
Device error x	Internal device error	<ul style="list-style-type: none"> Press the TEST button Switch the supply voltage off and on Contact Bender service 		SERVICE is lit
Overtemperature coupling	Overtemperature coupling terminal L1/+ or L2/-	<ul style="list-style-type: none"> Check mains voltage level. The device connects itself again automatically after the cool-down period 		SERVICE is lit
Overtemperature PGH	Overtemperature of the locating current injector	<ul style="list-style-type: none"> Wait for the end of the cool-down period 		SERVICE is lit
Check date and time!	Date and time have not been set yet	<ul style="list-style-type: none"> Set local date and time (buffer of three days in case of voltage failure) 	See chapter “Clock” ab Seite 35.	

14.1 Response time profile Power circuits

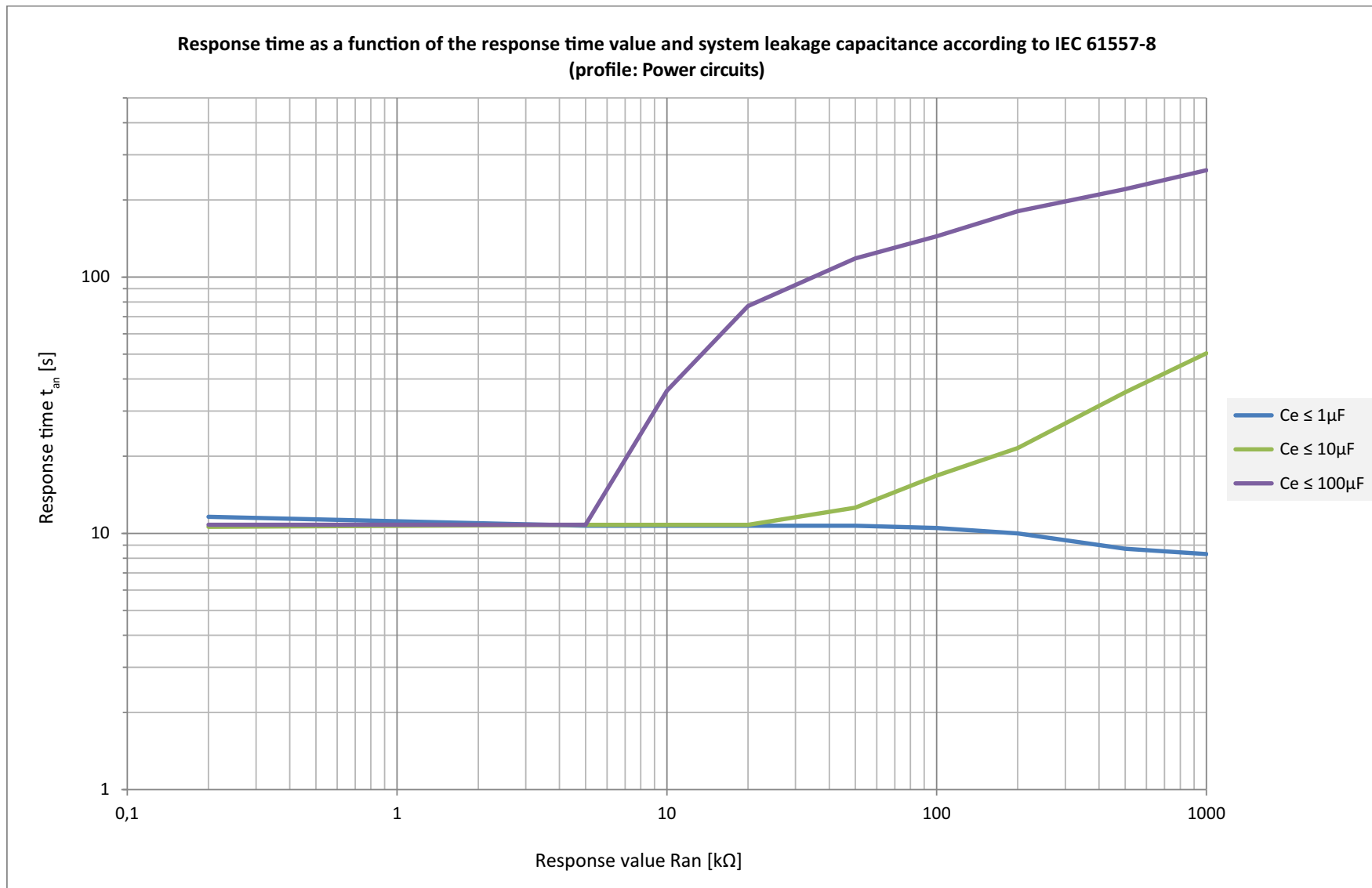

14.2 Response time profile High capacitance

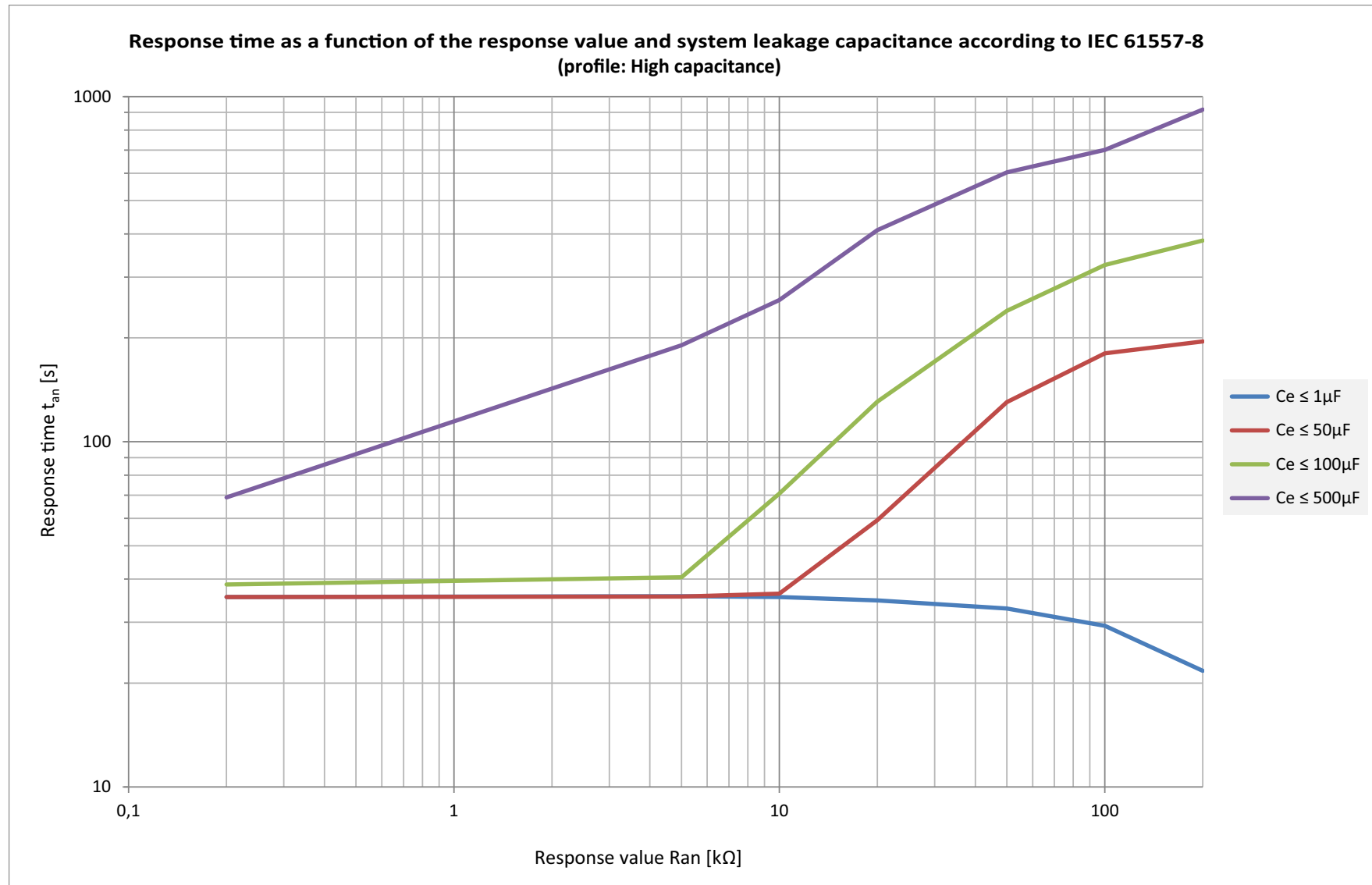

14.3 Response time profile Inverter > 10 Hz

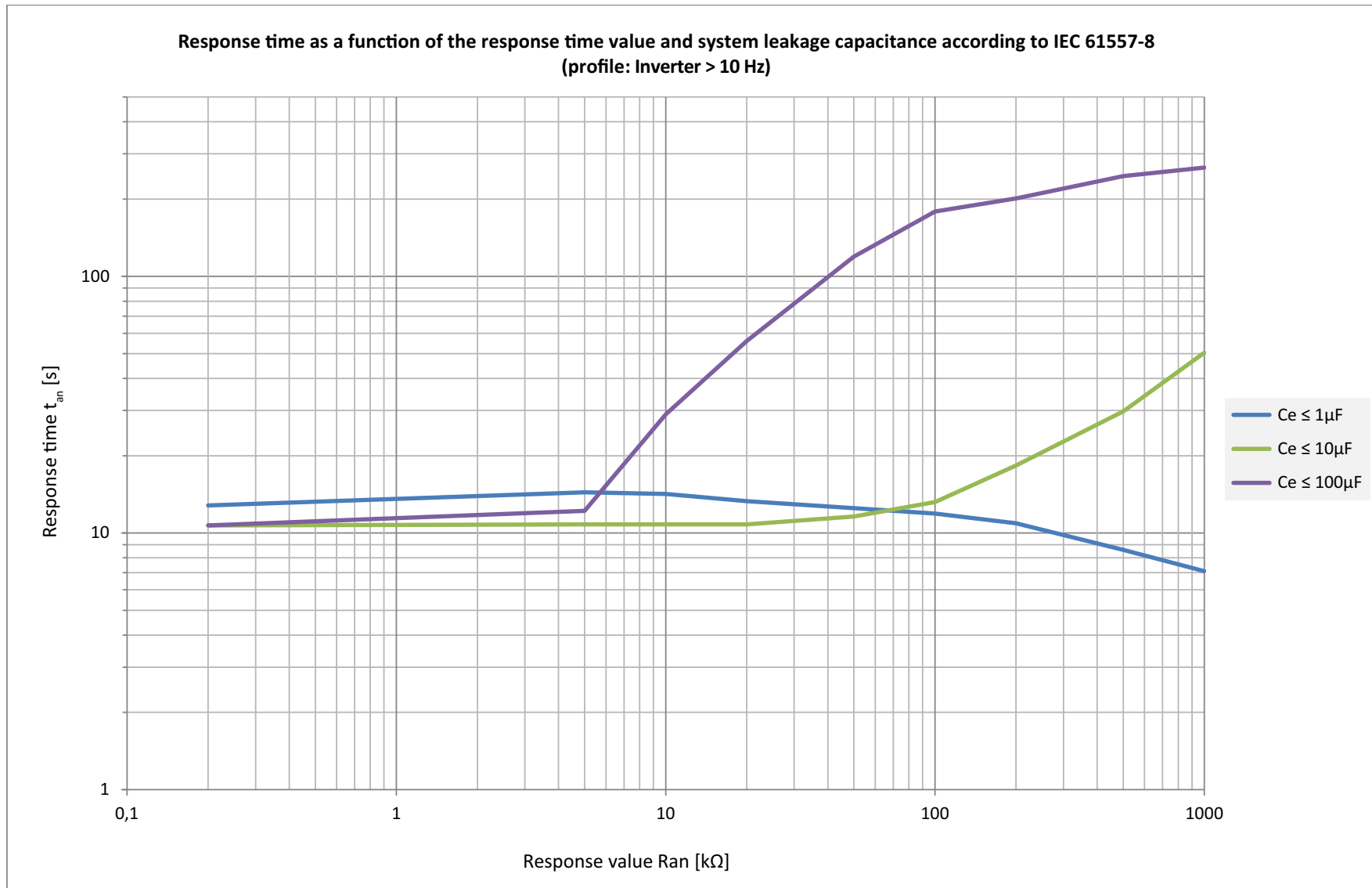

14.4 Response time profile Inverter < 10 Hz

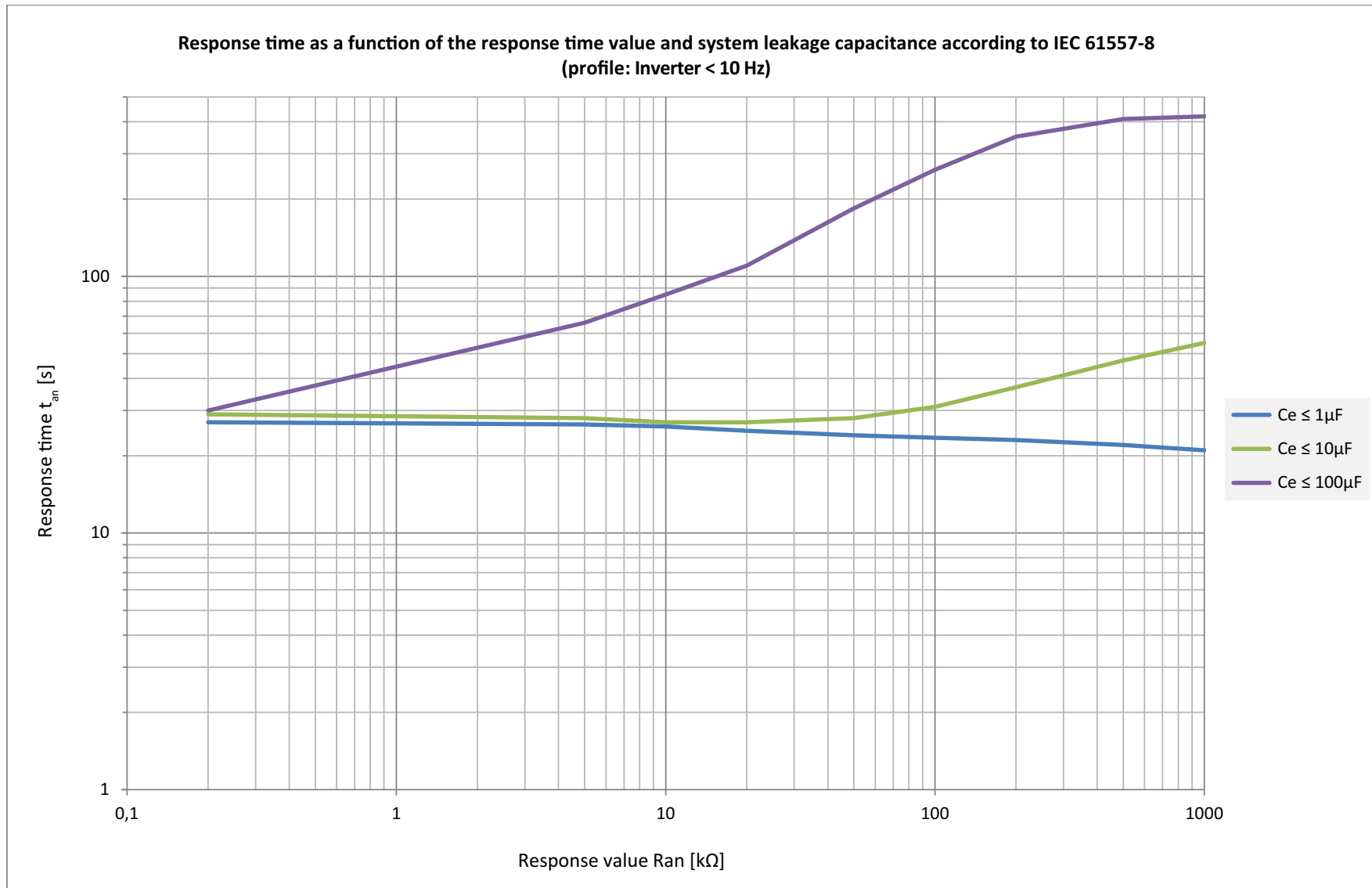

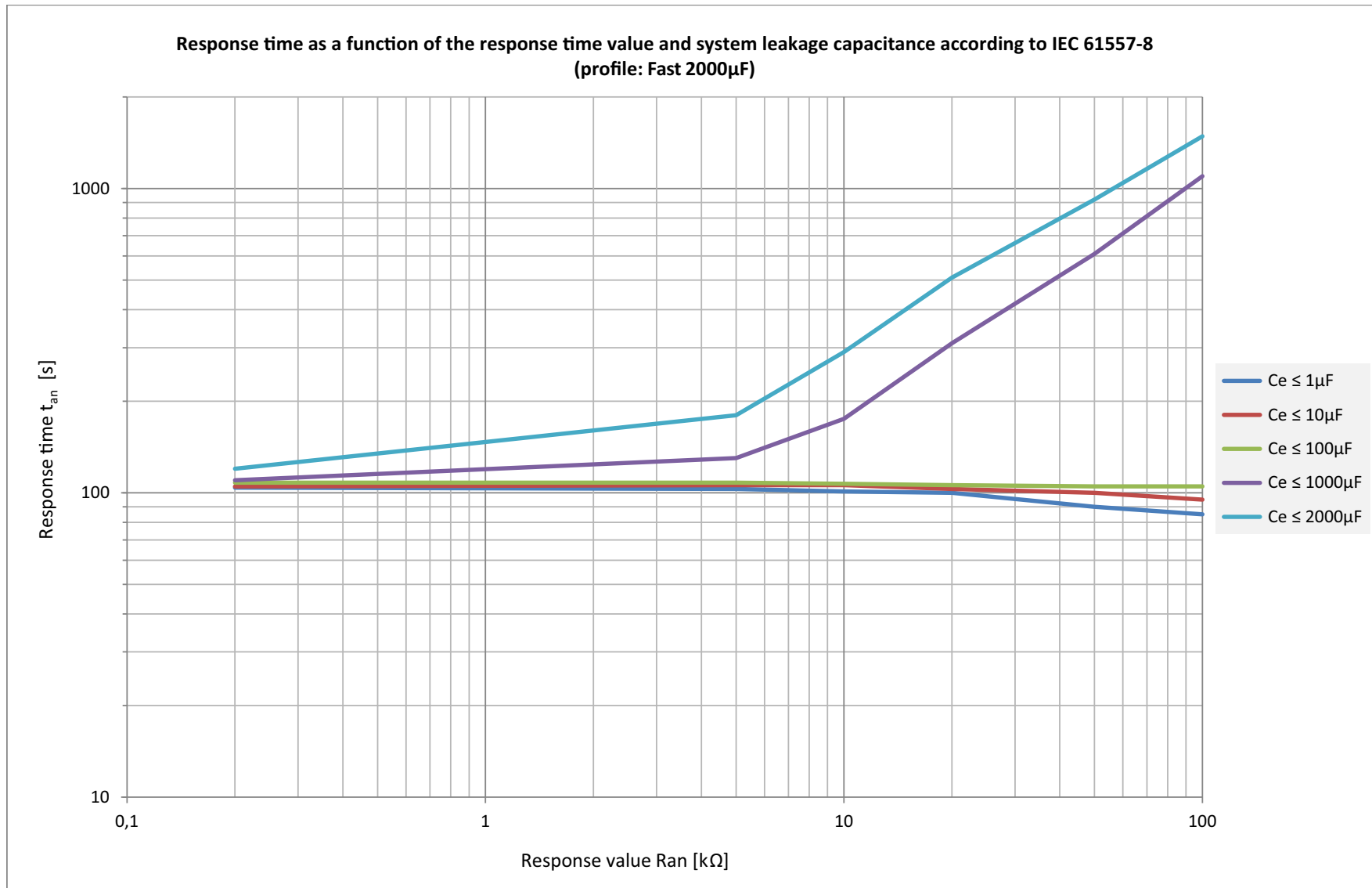
14.5 Response time profile Fast 2000 μF 

14.6 Leakage capacitance

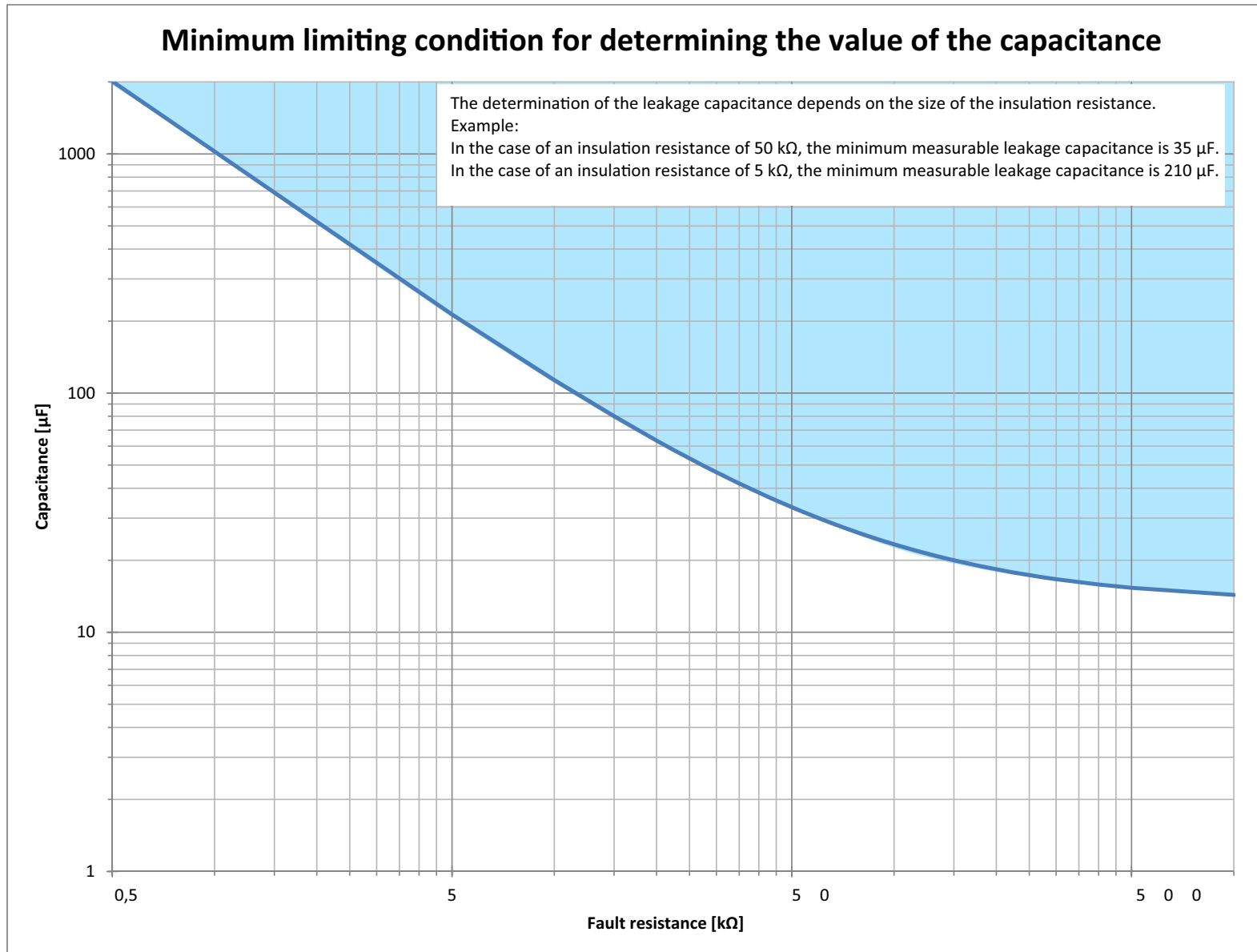

15.1 Tabular data iso1685DP

()* = Factory settings

Insulation coordination acc. to IEC 60664-1/IEC 60664-3

Insulation coordination according to IEC 60664-1

Rated voltage.....	DC 1500 V
Overtoltage category (OVC).....	III
Rated impulse withstand voltage	8 kV
Rated insulation voltage.....	1500 V
Pollution degree exterior.....	3
Voltage test, routine test (IEC 61010-1)	2.2 kV

Voltage ranges

Nominal system voltage range U_n	AC 0...1000 V/DC 0...1500 V
Tolerance of U_n	AC +10%/DC +5%
Frequency range of U_n	DC, 1...460 Hz
Supply voltage U_s (see also device nameplate)	DC 18...30 V
Frequency range of U_s	DC
Power consumption	≤ 9 W

Measuring circuit for insulation monitoring

Measuring voltage U_m (peak value)	±50 V
Measuring current I_m (at $R_F = 0 \Omega$)	≤ 1.5 mA
Internal DC resistance R_i	≥ 70 kΩ
Impedance Z_i at 50 Hz	≥ 70 kΩ
Permissible extraneous DC voltage U_{fg}	≤ DC 1500 V
Permissible system leakage capacitance C_e	profile dependent, 0...2000 μF
Measuring range leakage capacitance	20...2000 μF
Tolerance measurement of C_e	±10% ±10 μF
Frequency range measurement of C_e	DC, 30...460 Hz

Response values for insulation monitoring

Response value R_{an1} (alarm 1)	200 Ω...1 MΩ (40 kΩ)*
Response value R_{an2} (alarm 2)	200 Ω...1 MΩ (10 kΩ)*
Condition response value	$R_{an1} \geq R_{an2}$
Upper limit of the measuring range when set to $C_{emax} = 2000 \mu F$	50 kΩ
Upper limit of the measuring range when set to $C_{emax} = 500 \mu F$	200 kΩ
Relative uncertainty (10 kΩ...1 MΩ) (acc. to IEC 61557-8)	±15%
Relative uncertainty (0.2 kΩ...< 10 kΩ)	±200 Ω ±15%
Hysteresis	25%

Time response

Response time t_{an} at $R_F = 0.5 \times R_{an}$ ($R_{an} = 10 \text{ k}\Omega$) and $C_e = 1 \mu F$ acc. to IEC 61557-8
profile dependent, typ. 10 s

Measuring circuit for insulation fault location (EDS)

Locating current I_L DC	≤ 50 mA
Test cycle/pause	2 s/4 s

Indication

Display.....	graphic display 127 x 127 pixel, 40 x 40 mm
Display range measured value	0.2 kΩ...50 MΩ

LEDs

ON (operation LED)	green
PGH ON	yellow
SERVICE	yellow
ALARM 1	yellow
ALARM 2	yellow

Digital inputs

Operating mode, adjustable	active high, active low
Functions.....	none, test, reset, deactivate device, insulation fault location
High level	10...30 V
Low level	0...0.5 V

Serial interface

Interface/protocol	RS-485/BMS
Connection	terminals A/B
Cable length	≤ 1200 m
Shielded cable (shield to functional earth on one end)	2-core, 30.6 mm ² , e.g. J-Y(St)Y2x0.6
Shield.....	terminal S
Terminating resistor, can be connected (Term. RS-485)	120 Ω (0.5 W)
Device address, BMS bus	(1) 2...90 (2)*

Switching elements

Switching elements..... 3 changeover contacts: K1 (insulation fault alarm 1), K2 (insulation fault alarm 2), K3 (device error)
 Operating principle K1, K2 N/C operation or N/O operation (N/C operation)*
 Operating principle K3 N/C operation, cannot be changed
 Electrical endurance under rated operating conditions, number of cycles 100,000
 Contact data acc. to IEC 60947-5-1:
 Utilisation category AC 13 AC 14..... DC-12.... DC-12 .. DC-12
 Rated operational voltage 230 V 230 V.....24 V..... 110 V220 V
 Rated operational current 5 A 3 A..... 1 A..... 0.2 A ... 0.1 A
 Rated insulation voltage.....250 V
 Minimum contact rating 1 mA at AC/DC ≥ 10 V

Connection (except system coupling)

Connection type..... pluggable push-wire terminals
 Connection, rigid/flexible..... 0.2 .. 2.5 mm²/0.2 .. 2.5 mm²
 Connection, flexible with ferrule, without/with plastic sleeve 0.25 .. 2.5 mm²
 Conductor sizes (AWG) 24 .. 12

Connection of the system coupling

Connection type..... pluggable push-wire terminals
 Connection, rigid/flexible..... 0.2 .. 10 mm²/0.2 .. 6 mm²
 Connection, flexible with ferrule, without/with plastic sleeve 0.25 .. 6 mm²/0.25 .. 4 mm²
 Conductor sizes (AWG) 24 .. 8
 Stripping length..... 15 mm
 Opening force 90 .. 120 N

Environment/EMC

EMC IEC 61326-2-4
 Classification of climatic conditions acc. to IEC 60721:
 Stationary use (IEC 60721-3-3) 3K5 (except condensation and formation of ice)
 Transport (IEC 60721-3-2) 2K3
 Long-term storage (IEC 60721-3-1) 1K4
 Classification of mechanical conditions acc. to IEC 60721:
 Stationary use (IEC 60721-3-3) for iso1685DP 3M4
 Transport (IEC 60721-3-2)..... 2M2
 Long-term storage (IEC 60721-3-1) 1M3
 Deviation from the classification of climatic conditions:
 Ambient temperature during operation -40 .. +70 °C
 Ambient temperature transport -40 .. +80 °C
 Ambient temperature long-term storage -25 .. +80 °C
 Area of application ≤ 3000 m AMSL

Other

Operating mode continuous operation
 Position of normal use vertical, system coupling on top
 Tightening torque of the screws for enclosure mounting 1.0 .. 1.5 Nm
 Degree of protection, internal components IP30
 Degree of protection, terminals..... IP30
 Enclosure material polycarbonate
 Flammability class V-0
 Weight ≤ 1600 g

15.2 Standards and certifications

The iso1685DP was designed according to the following standards:

- DIN EN 61557-8 (VDE 0413-8)
- IEC 61557-8
- DIN EN 61557-9 (VDE 0413-9)
- IEC 61557-9
- IEC 61326-2-4
- DIN EN 60664-1 (VDE 0110-1)



15.3 Ordering details

Type	Response value range	Nominal voltage	Supply voltage *	Art. No.
iso1685DP-425	200 Ω...1 MΩ	AC 0...1000 V DC 0...1500 V	DC 18...30 V	B91065802

The data labelled with an * are absolute values.

A

- Ableitkapazität 50
- Address setting 10
- Alarm
 - Messages 44
- Alarm messages 40
- Alarm relays 11
- and certifications 52
- Ansprechzeit
 - Profil Umrichter 45

B

- BMS bus 36, 38
 - Address setting 39
 - Alarm messages 40
 - Commissioning 39
 - Master 39
 - Number of bus nodes 39
 - Operating messages 40
 - Protocol 39
- Button/Key 16
- Buttons 16

C

- Clock 23, 35
- commissioning flow chart 22
- Commissioning wizard 23
- Connect the device 19, 20
- Connection
 - Connection requirements 17
- Connections 15
- Coupling monitoring 31

D

- Date 23, 35
- Device buttons 16

- Device features 10
- DIP switch 16
- Display 26
 - Fault display (active) 26
 - Fault display (inactive) 27
 - Fault memory 27
 - History memory 28
 - Signal quality of the measurement 26
- Display and operating elements 16

F

- Factory settings 22
- Function description 10

H

- History memory 28

I

- Indication 26
 - Limit values for R(an) 26
- Inputs 31
- Installation of the device 17
- Insulation fault location 11
- Insulation monitoring 11
- Interface 36

L

- Language 23, 35
- LEDs
 - ALARM 1 16
 - ALARM 2 16
 - ON 16
 - PGH ON 16
 - SERVICE 16
- Locating current injector 11

M

Mains frequency 43
Measured value transmission 12
Measured values 34
Memory card 16

N

Nominal system voltage 43

O

Operating elements
 Button/Key 16
 DIP switch 16
 Memory card 16
Operating messages 40
Output 32

P

Parameterisation of the insulation fault location 11
Password 36
Profil
 Umrichter 45, 47, 48, 49
Profile overview 43

R

Resetting error messages 40
RS-485 interface 38
RS-485 network
 Correct arrangement 38
 Wrong arrangement 38

S

Safety instructions 8
Self test 24
 after connection to the supply voltage 12
 Automatic 13

Manual 13

Service menu 36

Settings

 Alarm 30
 Basic settings 34
 Coupling monitoring 31
 Date and time 23, 35
 Inputs 31
 Interface 36
 Language 23, 35
 Manual test 34
 Measured values 34
 Measurement insulation resistance 31
 Password 36
 Profile 24, 30
 Reset alarm message 34
 Response value Ran1, Ran2 24
 System type 23

Signal quality of the measurement 26

Standards 52

Standby mode 12

System leakage capacitance 43

T

terminated RS-485 network 38

Terminating resistor 38

Termination 9

W

Wiring diagram 19, 20, 21

Work activities on electrical installations 10



Bender GmbH & Co. KG

Postfach 1161 • 35301 Grünberg • Germany
Londorfer Straße 65 • 35305 Grünberg • Germany

Tel.: +49 6401 807-0
Fax: +49 6401 807-259

E-Mail: info@bender.de
Web: www.bender.de

Kundendienst

Service-Hotline: 0700-BenderHelp (Telefon und Fax)
Carl-Benz-Straße 8 • 35305 Grünberg • Germany

Tel.: +49 6401 807-760
Fax: +49 6401 807-629

E-Mail: info@bender-service.com
Web: <http://www.bender.de>



BENDER Group